

S Series

Installation Operation Maintenance Manual



www.thermodynamicsboiler.com

Thermo-Dynamics Boiler Company

ROUTE 61 • P.O. BOX 325 • SCHUYLKILL HAVEN, PA 17972
(570) 385-0731 FAX (570) 385-5304

Service Policy

Congratulations on the purchase of your boiler. Here at Thermo-Dynamics Boiler Company we pride ourselves on the design and construction of our product. Our intent is to furnish you with a high quality appliance that will provide you and your family with years of trouble free service.

In order to maintain peak performance of your boiler, it is recommended that the burner/boiler be serviced annually, preferably prior to the onset of the winter heating season. Servicing of your appliance must be performed by a qualified heating technician. You should utilize a qualified heating technician familiar with your installation to manage your heater and perform periodic maintenance. Proper care and maintenance of your boiler will allow you to enjoy the benefits of your new purchase as well as extend its long useful life.

In the event that your serviceman encounters difficulty with the boiler, he/she shall contact the distributor from which the product was purchased. The distributor shall, in turn, contact the Thermo-Dynamics sales representative for your area. By adhering to this protocol, Thermo-Dynamics wishes to provide you with responsive and unparalleled service. We realize the importance that our product means to you and your family and our goal is to get your heater up and running as quickly as possible.

Thank you for purchasing the Thermo-Dynamics boiler. Again, it is our intent to provide you with a high quality trouble free product that will be part of your family for many years to come. Please consider Thermo-Dynamics Boiler Company in the future for all of your home heating needs.



Contents

<i>Subject</i>	<i>Page</i>
Read This First	2
Specifications	4
Installation	4
Operational Sequence	7
Start-Up	8

Appendices

Troubleshooting Guide	A
Dimensions and Jacket Assembly	B
Specifications	C
Piping Diagram	D
Wiring Diagrams	E
Installer/Service Technician Labels	F
Appendix	G

Read This First

1. *Installer must be a trained, experienced technician and should read all instructions before installation.*
2. *Inspect the boiler, jacket and all components to be sure damage has not occurred in shipment. If damage is evident a claim must be filed with the freight carrier who transported the boiler from the factory to the distributor where it was purchased. Do not install the boiler. Contact your distributor.*
3. *Disconnect power supply before connecting wiring.*
4. *Refer to local codes for oil burning equipment, for recommended installation practice. You will need to be familiar with NFPA International Standard 31, "Standard for the Installation of Oil Burning Equipment".*
5. *A complete heat loss calculation is necessary to choose the proper size unit to install. The boiler should be sized to within 25% of the actual heat loss of the structure. Over sizing will result in short cycling and inefficient operation.*
6. *When moving the boiler, do not push against the jacket or burner. Damage will result.*
7. *If the boiler is vented to a chimney, be certain the chimney is clean and free of obstructions. The chimney must be masonry with tile lining or metal insulated with a stainless steel surface. The Chimney must be properly sized. Draft requirements are essential for safe and proper operation of the boiler.*
8. *If the boiler is connected to a venting device, make sure that it is listed by a recognized testing service. Follow the venting device manufacturer's installation instructions. Verify that the venting device installation complies with the recommendations of the manufacturer and local and state codes.*
9. *Conduct a thorough checkout when installation is complete. Check for indications of leaks and make sure that no material is left adjacent to the boiler.*

10. *The use of low sulfur No. 2 heating oil is highly recommended.*
11. *Modification, substitution or elimination of factory equipped, supplied or specified components may result in property damage, personal injury or the loss of life.*
12. *The following definitions apply to potential hazards noted in this manual.*

DANGER: *Indicates a hazardous situation which if not avoided will result in death or serious injury.*

WARNING: *Indicates a hazardous situation which if not avoided could result in death or serious injury.*

CAUTION: *Indicates a hazardous situation which if not avoided, may result in a minor injury. It may also warn against unsafe practices that may result in minor injury or damage to equipment.*

NOTICE: *Indicates that special attention to information is required. Not related to personal injury or property damage.*

A. Installation Instructions

- 1) Place the boiler on a level floor, preferably raised and as close to the chimney as possible. The boiler must be installed on a non-combustible surface. The minimum clearances for installation are shown below. Reduced clearance installations must follow NFPA-31 guidelines. If the boiler is a Knock Down (not packaged for ease of installation), install the jacket in accordance with the directions provided in the jacket package, prior to piping.

Standard Clearances	
Front	24"
Sides	6"
Rear	6"
Chimney Connector	18"

WARNING: The boiler must be installed on a non-combustible surface or fire may result.

- 2) Install the boiler piping. For location of piping refer to the Installation Drawing.

DANGER: Boilers with tankless coils must be piped in accordance with the piping diagram including installation of a tempering or mixing valve. Domestic hot water temperatures exceeding 125°F will cause severe burns instantly or death by scalding.

WARNING: Relief valve discharges and drain valve piping must be piped to a safe place of discharge.

NOTICE: S Series Boilers are provided with a built-in air scoop feature. This feature allows quiet, air free operation of the hot water system by eliminating air pockets without installation of air scoops. The supply line tapping in the top of the boiler extends approximately 1 inch below the top of the boiler, allowing only air-free water to enter the heating system supply. Any air trapped in the top of the boiler is purged through the 3/4" vent tapping. The 3/4" vent tapping should be connected to an automatic float vent, a manual vent or piped to a conventional expansion tank. See Appendix B for illustration.

- 3) Packaged boilers are shipped with the burner, aquastat and circulator installed and wired at the factory. See the Basic Wiring Diagram for wiring schematic. See component manufacturer's manual for wiring instructions.
- 4) An expansion tank, not provided, must be matched to the system and installed in accordance with the manufacturer's instructions. Do not undersize the expansion tank. An automatic feed and pressure reducing valve, not provided, should be installed in the water inlet line to keep the entire system from falling below the pressure setting of the valve (about 12 psi) See the feed valve suppliers instructions for maximum allowed water supply pressure and requirements for pressure reducers. For piping and wiring of other system components see the manufacturer's installation manuals.
- 5) The tank-less water heater may be piped as shown in the Installation Drawing. A mixing valve (tempering valve), not supplied, must be used to reduce the water temperature at

kitchen or bathroom taps. High temperature water for a dishwasher may be obtained by piping as shown in the Installation Drawing. The nuts that secure the tank-less coil flange should be tightened before the boiler is filled with water, after initial firing and once a year during the annual maintenance.

CAUTION: Deterioration due to coil gasket leaks will void the warranty.

- 6) Connect boiler flue outlet to chimney using galvanized smoke pipe. Use only high quality lock seam smoke pipe. The flue pipe should be pitched upward at least 1/4" per foot of run. Refer to the boiler specifications for proper size flue pipe for your model boiler. Use only elbows and straight sections. Tees may be used in a straight section in conjunction with a barometric draft regulator however they must not be used for a 90° turn. Each joint should be securely fastened with sheet metal screws. The flue pipe must not be inserted beyond the inside wall of the chimney. Install barometric draft regulator in the horizontal or vertical section of the flue pipe. The draft regulator should be installed in accordance with the manufacturer's instructions. Set the draft to in the stack as specified in the boiler specifications and on the Installer/Service Man Label on the boiler jacket. The flue gas exit of the venting system should be at designed with clearances in accordance with NFPA 31. A chimney must be at least 3 feet above the highest point where it passes through the roof and at least 2 feet higher than any portion of a building within 10 feet of the venting system. The horizontal length of a chimney connector should not exceed 10 feet unless a draft booster is used. Where the possibility of down drafts exist, install a listed vent cap.

WARNING: Installation and venting with improper materials or methods may result in serious injury or death due to asphyxiation from poisonous gases such as carbon monoxide. A carbon monoxide detector should be installed per the manufacturer's instructions.

- 7) The boiler room must be well ventilated to allow sufficient make-up air to support combustion. Lack of adequate combustion air may result in erratic operation of the burner, noisy combustion or fuel odors. Remember your need for outside air will be greatly increased if you have a vented dryer in the basement or other venting fans in the home. Boilers located in confined spaces shall be provided with two permanent openings, one near the top and one near the bottom of the enclosure. Each opening shall have a free area of not less than one square inch per 1000 BTU per hour input rating of the boiler, freely communicating with interior areas having adequate infiltration from the outside.
- 8) Fill boiler and system with water. Be sure entire system has been purged of air and the desired pressure is obtained. Leak-check the boiler and piping system by turning off the make-up water supply and observing the boiler pressure gage. A loss of pressure indicates a system leak that must be repaired prior to operating the boiler.
- 9) Remove the nozzle line assembly and check that the correct nozzle is installed for the desired firing rate. Check that burner settings are correct for the nozzle that is installed. See the Installer/Service Man Label.
- 10) Connect burner to oil supply. Refer to fuel unit manufacturer literature for piping, connections, lift and tank installation. If such information is unavailable use the following guide lines.

FUEL UNITS/FUEL LINES

Fuel supply "level with" or "above" burner: A single stage fuel unit connected to the fuel supply with a single supply line is the most common type of installation for these conditions. Manual venting of the fuel unit is usually required on initial start-up. Failure to vent air could result in an air lock/oil starvation condition. (One pipe)

Fuel supply below the level of burner: Use a single stage fuel unit in lift conditions of up to 10 ft., and a two stage fuel unit when the lift exceeds 10 ft. Both conditions require the use of a return line which purges the fuel unit of air returning it to the fuel tank. The "by-pass" plug must be inserted into the fuel unit when installing a return line. (Two pipe)

Fuel line installation: Continuous lengths of heavy wall copper tubing are recommended and should be installed under the floor when possible. Always use flare fittings. Always install fittings in accessible locations. Never use teflon tape on any fuel fitting. Use of teflon will void any warranty. Fuel lines should not run against the appliance or the ceiling joists.

Fuel line valve and filter: Install two high quality shutoff valves in accessible locations on the oil supply line. Locate one close to the tank and the other close to the burner ahead of the filter. Some filters come with built-in shutoff valves. Install a generous capacity filter inside the building between the fuel tank shutoff valve and the burner locating both the filter and the valve close to the burner for ease of servicing.

CAUTION: All oil feed lines to burners must be air tight. Use only flare fittings when assembling oil lines since the slightest air leak, caused by loose fittings, bad gaskets or any other reason, can cause a foaming oil stream which will cause any of the following conditions:

- a) Intermittent firing, causing safety shutdown
- b) Poor starts
- c) Smokey starts
- d) Continual sooting of boiler and burner parts including the cad cell
- e) Reduced firing rate, inefficient operation and erratic fire pattern
- f) A dangerous combustion condition, allowing the firebox to fill with a lean mixture (too much air in the oil stream) which could cause a delay in ignition of the fuel mixture until the danger point has been reached.

Suction Vacuum Test. A fuel pump suction vacuum test should be performed. See the fuel pump manufacturers literature for details. The suction vacuum must be limited to ensure that there is adequate pump lift. This problem becomes proportionately larger with underground tanks. If the following procedures are followed, burner related problems will be minimized:

- a) Connect vacuum gauge to oil pump. Suction vacuum must not exceed 10 inches of mercury for single stage pumps and 15 inches for two stage pumps. It is preferable to stay below these limitations.
- b) When the suction line is tight and properly installed the pump will hold its vacuum for a minimum of 60 minutes after shutdown.
- c) Installation of a check valve in the suction line of a two pipe system is advisable under all circumstances. Be sure the check valve fittings are airtight.

- 11) Connect the electric supply to the boiler as indicated on the wiring diagram. The wiring must be installed in accordance with the National Electrical Code and any other state and local codes and the following requirements.
 - a) Internal wiring is completed at the factory on packaged boilers. External wiring must conform with the National Electric Code and local codes.
 - b) Field connections should be protected with a 15 amp fuse.
 - c) A separate, fused disconnect switch should be installed and located near the unit so that power can be shut-off for servicing, unless already equipped.
 - d) Install the room thermostat (not provided) on an inside wall away from cold drafts, windows or heat from fireplaces, appliances or sunlight. Set the heat anticipator in accordance with the manufacturer's instructions. Connect the thermostat leads to the "TT" terminals on the circulator control.

C. Operational Sequence

- 1) S Boilers equipped with tankless coil are equipped with a combination aquastat control which has high and low limits to be set at 180° F and 160° F respectively by the installer. These settings are nominal and may be adjusted for the particular installation conditions. A 20° F difference between high and low limit is recommended. The control prioritizes domestic hot water heating as explained below.
 - a. When room temperature falls below thermostat setting, thermostat calls for heat starting the burner and circulating pump. The burner and pump continue to operate until room heating requirements are satisfied (thermostat setting is reached), or until boiler water temperature reaches the high limit control temperature setting. If the high limit control temperature setting is reached, the burner shuts off and the circulating pump continues to operate until the room heating requirements are satisfied. If the thermostat continues to call for heat after the boiler water temperature has dropped to approximately 10 degrees below the temperature setting of the high limit control, the oil burner will start again and the circulating pump will continue to run.
 - b. The boiler water temperature is normally maintained at 160°F around the tankless coil by the operating control so that an abundance of hot water is available. If the boiler water temperature should fall approximately 10 °F below the operating control low limit setting, the oil burner will be started again by the control (and the circulating pump will be prevented from operating) until the operating control setting is satisfied. The operating control has an adjustable low limit differential setting. The low limit differential setting determines how high the boiler temperature must rise before the burner turns off and or the circulator comes on if the thermostat calls for heat. The differential is measured from 10°F below the low limit. See control manufacturer's literature included in the data package for detailed wiring, operating and safety instructions.
 - c. Adjusting the low limit differential to higher values will provide priority to heating domestic hot water over a greater range of boiler temperature. (Maximum of approximately 25°F differential measured from 10°F below the low limit setting.)

- 2) S boilers not equipped with a tankless coil are may be provided with a high limit aquastat control which should be set at 180°F by the installer. This setting is nominal and may be adjusted for the particular installation conditions.
 - a. When room temperature falls below thermostat setting, thermostat calls for heat starting the burner and circulating pump. The burner and pump continue to operate until room heating requirements are satisfied (thermostat setting is reached), or until boiler water temperature reaches the high limit control temperature setting. If the high limit control temperature setting is reached, the burner shuts off and the circulating pump continues to operate until the room heating requirements are satisfied. If the thermostat continues to call for heat after the boiler water temperature has dropped to approximately 15 degrees below the temperature setting of the high limit control, the oil burner will start again and the circulating pump will continue to run.
 - b. The boiler water temperature need not be maintained at a 160°F low limit setting since there is no domestic hot water load to protect. See control manufacturers literature included in the data package for detailed wiring, operating and safety instructions.
 - c. Boilers without Tankless Coils may be equipped with a combination aquastat that has a high and low limit setting. The high limit control is set at 180°F and the low limit is set based on the application. If the boiler is used with an indirect hot water heater for domestic hot water, the low limit is set at 160°F to support the operation of the indirect hot water heater. If the an indirect hot water heater is not used, the low limit may be set between 120°F and 140°F to provide protection against condensation in the boiler. The settings are nominal and many be adjusted for the particular installation conditions.
- 3) A cadmium sulfide flame scanner (cad cell) and relay are provided with the oil burner. The cad cell will stop the oil burner within a predetermined number of seconds if the fuel fails to ignite or if the flame goes out during operation. The oil burner will remain off until the red reset button on the relay has been pushed. Reset must never be pressed more than once during a single flame failure.

D. Start-Up and Check-Out Procedure

CAUTION : Only a trained, experienced serviceman should attempt the checkout procedure outlined below. You should read to the burner manual provided with this manual for specific instructions and set points.

- 1) Confirm that electrical power to the boiler is off. The fuel tank must be filled with No. 2 heating oil. Low Sulfur fuel is preferred.
- 2) Check electrode settings, nozzle size and air setting. Electrode settings are shown in the burner manual provided along with this manual. Burner settings are listed on the Service Man's Label attached to the boiler and on the Specifications provided along with this manual.
- 3) Set thermostats substantially above room temperature.
- 4) Open all shut-off valves in the oil supply line to the burner.

- 5) Install pressure gauge in the port provided on the oil pump. Attach a length of 1/4" O.D. clear plastic tubing to the end of the bleed plug.
- 6) Turn on power to the boiler. If burner does not start immediately reset manual overload switches and control. See control manual for reset instructions.
- 7) On one pipe systems bleed the oil pump as soon as burner motor starts. To bleed the pump, loosen plug while holding an empty container under the tubing installed in step 6 to catch all of the expelled oil. Bleed for at least 15 seconds after the oil stream is free of all air. If air is still evident in the bleed line you must check the oil lines, all fittings, filters and any other connections for tightness. Kinks in the oil lines will create undue high vacuum therefore they must be eliminated. When you are sure all air has been eliminated then close the bleed valve. Ignition should be instantaneous following the closing of this valve. If it is not, proceed to the trouble shooting guide to determine why the oil did not ignite.
- 8) Be sure the oil pump discharge pressure is adjusted to the pressure listed on the Installer/Service Man Label. If it is not, refer to the burner manufacturer's instruction sheet for pressure adjustment procedure.

FINAL ADJUSTMENTS OF THE BURNER MUST BE MADE USING PROPER COMBUSTION TEST EQUIPMENT. Combustion test equipment required for proper burner adjustment:

- a) CO₂ Analyzer
- b) Draft Gauge
- c) Oil Pressure Gauge 0-200 PSI
- d) Stack Thermometer
- e) Smoke Test Gun
- f) Vacuum Gauge 0-30 in. of Hg

Notice: Read the burner manufacturer's instructions supplied with this manual to set combustion. The burner instructions contain special instructions that may apply to the model supplied with your boiler including how special features may affect the set-up procedure.

- 10) Burner Adjustments. Allow the burner to operate steadily for 5 to 15 minutes. Check burner settings shown on the Installer/Service Man Label and make the following adjustments.
 - a. Punch or drill a 1/4" hole in the flue pipe between the boiler and the barometric draft regulator. All test readings should be taken from this point.
 - b. Take a draft reading from the flue pipe sampling hole. Adjust the draft in the stack, using the barometric draft regulator, to the value shown on the Installer/Service Man Label. In tall chimneys a second draft regulator may be required in the flue pipe to regulate draft under high draft conditions.
 - c. Remove the draft port plug over the fire and take a draft reading from the draft port. Compare the readings with those on the INSTALLER/SERVICEMAN label. Refer to the trouble shooting procedure if the draft over the fire reading is not correct. Reinstall the draft port plug after all readings have been taken.

- d. Follow the burner manufacturer's instructions to adjust the air supply until a trace of smoke is recorded. At the trace of smoke level, measure the CO₂. This is the reference point for all further adjustments.
 - e. Increase the air supply to reduce the CO₂ about 1 % to 2% from the reference point. A zero smoke reading should result. If this adjustment can not be obtained, refer to the Trouble Shooting section of this manual.
 - f. When combustion is set, follow the burner manufacturer's instructions to lock or tighten adjustment mechanisms as required.
- 11) Check operation of the cad cell relay by removing one cad cell wire from external terminal during the flame cycle. The relay should cut the burner off in approximately 15 sec.

E. Servicing the Boiler/Burner Unit:

- 1) Burner Components: If replacement of burner parts is necessary, always use parts recommended by the manufacturer. Specify part number and description when ordering.
- 2) Electrode settings are important for reliable ignition of the oil. Check to be sure the settings are in accordance with the instructions provided in the burner manual.
- 3) Nozzles: The nozzle specifications listed in the manual are the result of years of exhaustive engineering testing. Use extreme care in handling nozzles to avoid scratches or dirt that could cause leaks or affect the oil spray pattern.

CAUTION: Any nozzle replacement should be of the exact type as listed in the specifications.

- 4) Fan and blower housing should be kept clean of dirt and lint. If heating unit is located near an unvented dryer, special care must be taken so that lint does not clog the burner air inlets.
- 5) Replace the oil filter cartridge annually.
- 6) Check all water connections and plugs for evidence of leaks. Check for leaks by shutting the make-up water supply valve. If boiler pressure decreases, it is evidence of a leak which must be repaired.
- 7) Cleaning the Boiler: Cleaning should be done only by a trained, experienced serviceman.

DANGER: Before cleaning turn off all power to the boiler. Failure to turn off power could result in firing the boiler when it is open.

- A) Remove the flue pipe, jacket top and flue cover.
- B) Remove baffles from the units and clean them. Brush all tubes with a #2 soft flue brush. Use a boiler vacuum to collect any residue.
- F) Inspect the burner head. Remove any accumulation on the burner. Inspect and follow burner manufacturer's recommendations for cleaning and maintenance.

- G) Check all refractory and gaskets for resilience and continuity. Replace damaged parts prior to re-assembling the unit.
 - H) Reassemble the boiler.
- 8) Replacing the combustion chamber. In the event that the combustion chamber is replaced, follow these instructions.
- A) Turn off power to the boiler and burner and shut off the oil supply to the burner.
 - B) Remove the burner assembly from the base.
 - C) Loosen the jacket at all sides.
 - D) Remove the four bolts at the corners of the boiler that secure the heat exchanger to the base.
 - E) Position bumper jacks at opposite corners of the lower tube sheet of the heat exchanger or use a come along on a lifter rig located at the top of the boiler through the flue box hole. A lifting lug is located just inside the flue box.
 - F) Raise the boiler about one inch or enough to slide the base out the front. The pipes should flex enough to raise the boiler heat exchanger.
 - G) Remove the soft chamber and replace. Replace the spacer block under the chamber if it is deteriorated.
 - H) Reinstall the firebox and reassemble the boiler.
 - I) Check boiler for proper operation.

Alternate chamber replacement procedure.

- A) Turn off power to the boiler and burner and shut off the oil supply to the burner.
- B) Remove the burner assembly from the base.
- C) Remove the burner mounting cover from the base. Using a utility knife cut around the flanged portion of the top of the chamber that is clamped between the boiler heat exchanger and the base. Break up and remove the remaining portion of the chamber.
- D) Using a utility knife, carefully trim the top flange of the new chamber to fit inside of the flange area.
- E) Lift the new chamber into the flange area creating a seal and support the new base with the spacer block.
- F) Reassemble the boiler.
- G) Check for proper boiler operation.

Troubleshooting Guide

TROUBLE: BURNER DOES NOT START

SOURCE	PROCEDURE	CAUSE	REMEDY
<i>Thermostat</i>	Check thermostat settings	Thermostat set too low.	Turn thermostat up.
		Thermostat on "off" or "cool".	Switch to heat.
		Open thermostat wires.	Repair or replace wires.
		Loose thermostat connectors.	Tighten connection.
		Faulty thermostat.	Replace thermostat.
		Thermostat not level.	Level thermostat.
<i>Circuit Overloads</i>	Check burner motor overload switch	Burner motor tripped on overload.	Push reset button.
	Check primary control safety switch.	Primary tripped on safety.	Reset safety switch.
<i>Power</i>	Check furnace disconnect switch and main disconnect switch.	Switch open.	Close switch.
		Tripped breaker or blown fuse.	Reset breaker or replace fuse.
<i>Cad Cell</i>	Jump the FF terminals on primary control. If the burner starts, fault is in detector circuit.	Open cad cell wires.	Repair or replace wires.
		Dirty cell face.	Clean face.
		Faulty cad cell.	Replace cad cell.
<i>Primary Control</i>	Check for line voltage between the black and white leads. No voltage indicates no power to the control.	Limit control switch open.	Check limit setting (200°).
			Jump terminals - if burner starts replace control.
		Open circuit between limit control and disconnect switch.	Repair circuit.
		Low line voltage or power failure.	Call utility company.
		Check for line voltage between orange and white leads. No voltage indicates a faulty control.	Defective control.
<i>Burner</i>	Check for voltage at the black and white leads to the burner motor. Voltage indicates power to motor and a fault in the burner.	Pump seized.	Turn off power to burner.
		Blower wheel binding.	Rotate blower by hand. Check for excessive drag. Replace fuel unit or blower wheel.
		Burner motor defective.	Replace burner motor.

TROUBLE: BURNER STARTS BUT DOES NOT ESTABLISH FLAME

SOURCE	PROCEDURE	CAUSES	REMEDY
<i>Oil Supply</i>	Check tank for oil.	Empty tank.	Fill tank.
	Check for water in oil tank using a dip stick coated with litmus paste.	Water in oil tank.	Strip tank of water exceeding 2" in depth.
	Listen for pump whine.	Fuel supply valve closed.	Open valve.
<i>Oil Line and Filter</i>	Open pump bleed port and start burner. Milky oil or no oil indicates loss of prime.	Air leak in fuel system.	Repair leak. Using only flared fittings. Do not use Teflon tape on oil fittings.
	Listen for pump whine.	Oil filter plugged.	Replace filter cartridge.
		Plugged pump strainer.	Clean strainer.
		Restriction in oil line.	Repair oil line.
<i>Oil Pump</i>	Install pressure gauge in port of fuel pump. Pressure should be 140 psi.	Pump worn - low pressure.	Replace pump.
		Motor overloads.	
		Coupling worn or broken.	Replace coupling.
		Pump discharge pressure set too low.	Set pressure at 140 psi.
<i>Ignition Transformer</i>	Connect transformer leads to line voltage. Listen for spark. Check that transformer terminals are not arcing with buss bars. Check that transformer is properly grounded.	No spark or weak spark.	Replace transformer.
		Line voltage below 102V.	Call utility company.
<i>Ignition Electrodes</i>	Remove and inspect draw assembly.	Carboned and shorted electrodes.	Clean electrodes.
		Eroded electrode tips.	Dress up tips and reset electrodes.
		Incorrect electrode settings.	
		Cracked porcelain insulators.	Replace electrodes.
<i>Nozzle</i>	Inspect nozzle for plugged orifice and distributor slots.	Plugged orifice or distributor. Plugged nozzle strainer. Poor spray pattern.	Replace nozzle with nozzle specified on burner housing.
	Inspect nozzle for correct size and specifications.	Incorrect nozzle installed.	Install correct nozzle.
<i>Combustion Air Adjustments</i>	Check air shutter and air band.	Air shutter open too far.	Decrease air shutter setting.
		Air band open too far.	Decrease air band opening.

TROUBLE: HGH NET STACK TEMPERATURES

SOURCE	PROCEDURE	CAUSES	REMEDY
<i>Nozzle</i>	Check pump pressure with pump gauge.	Nozzle overfiring due to high pump pressure.	Reduce pump pressure to 140 psi.
<i>Heat Exchanger</i>	Check heat exchanger surfaces for soot or scale fouling.	Heat exchanger fouled.	Clean heat exchanger.

TROUBLE: BURNER FIRES, BUT THEN LOSES FLAME

SOURCE	PROCEDURE	CAUSES	REMEDY
<i>Poor Fire</i>	Inspect flame for stability.	Unbalanced fire.	Replace nozzle with specified nozzle.
		Excessive draft.	Reduce draft setting.
		Insufficient draft.	Increase draft.
		Too little combustion air.	Increase combustion air.
<i>Oil Supply</i>	If burner loses flame prior to the primary control locking out, fault is in fuel system.	Air leak in fuel system.	Repair leak - use only flare fittings.
		Water in oil tank.	Strip tank of water exceeding 2" in depth.
		Fuel supply valve closed.	Open valve.
		Restriction in oil line.	Clear oil line restriction.
		Plugged fuel filter.	Replace filter cartridge.
		Plugged pump strainer.	Clean strainer.
		Cold oil.	Use #1 heating oil.
<i>Combustion Air</i>	Reduce combustion air supply.	Too much combustion air.	Close air band and air to raise CO ₂ .
<i>Pump</i>	Install pressure gauge in gauge port of fuel pump. Pressure should be 140 psi.	Pump discharge pressure incorrectly set.	Set pressure at 140 psi.
		Coupling worn or broken.	Replace coupling.
		Pump worn - low pressure motor overloads.	Replace pump.
<i>Excessive Draft</i>	Take a draft reading. Draft should be -.05"-.06" W.C. in stack.	Incorrect draft setting.	Reduce draft setting. Install second draft regulator if necessary.
<i>Poor Flue Gas Sample</i>	Insert CO ₂ probe into heat exchanger tube. If reading is greater by 1/2% or more, sample was being diluted near flue box.	Leak in flue system.	Sample CO ₂ in heat exchanger.
			Seal flue system leak.
<i>Testing Method</i>	Using a chemical absorption type device, let instrument set after a test before venting. If CO ₂ reading increases 1/2% fluid is weak.	Weak fluid.	Replace fluid in testing device.
<i>Nozzle</i>	Inspect nozzle for plugged orifice and distributor slots.	Plugged orifice or distributor. Plugged nozzle strainer. Poor spray pattern.	Replace nozzle with specified nozzle.

TROUBLE: INSUFFICIENT DOMESTIC HOT WATER

SOURCE	PROCEDURE	CAUSES	REMEDY
<i>Tankless Coil</i>	Analyze capacity vs. usage.	Insufficient coil capacity.	Install larger coil.
<i>Operating Control</i>	Check operating control setting.	Setting too low.	Set operating control to 180° F.
<i>Heat Exchanger</i>	Inspect coils for fouled surfaces and/or flow restrictions.	Flow restriction.	Remove restriction.
		Fouled surfaces on heat exchanger.	Clean heat exchanger surfaces.

TROUBLE: BURNER FIRES BUT PULSATES

SOURCE	PROCEDURE	CAUSES	REMEDY
<i>Draft</i>	Take a draft reading. Draft should be $-.05''$ $-.06''$ W.C. in the stack.	Down drafts. Insufficient draft. Excessive draft.	Install vent cap. Increase draft setting. Reduce draft settings, install second draft regulator if necessary.
<i>Draft Regulator</i>	Inspect draft regulator for correct location on flue system.	Improper installation.	Move draft regular to correct location.
<i>Combustion Air</i>	Inspect installation for combustion air provisions. Open air band wide and take CO ₂ reading.	Improper installation. Improper adjustment.	Provide openings that freely communicate with outside. Adjust CO ₂ level - start with air band wide open.
<i>Oil Supply</i>	Bleed pump; inspect for air leaks or water contamination.	Air leak in fuel system. Compression fittings. Water in oil tank.	Repair leak - use only flare joints. Strip tank of water exceeding 2" in depth.
<i>Pump Pressure</i>	Install pressure gauge in gauge port of fuel pump. Pressure should be 140 psi.	Pump discharge pressure incorrectly set. Coupling worn or broken. Pump worn - low pressure motor overloads.	Set pressure at 140 psi. Replace coupling. Replace pump.
<i>Nozzle</i>	Inspect nozzle for plugged orifice and distributor slots.	Plugged orifice or distributor. Plugged nozzle strainer. Poor spray pattern.	Replace nozzle with nozzle specified on burner housing.
<i>Heat Exchange Restrictions</i>	Take draft reading at flue box and read draft over the fire. Difference should not exceed $-.03''$.	Plugged heat exchanger.	Clean out heat exchanger.

TROUBLE: BURNER FIRES, BUT THEN FAILS ON SAFETY

SOURCE	PROCEDURE	CAUSES	REMEDY
<i>Cad Cell</i>	Check cad cell with ohmmeter. If more than 2000 ohms, cad cell is defective or dirty.	Faulty or dirty cad cell.	Clean or replace cad cell.
<i>Primary Control</i>	After burner fires open cad cell circuit if flame looks OK. If burner continues to operate, fault is in primary control.	Faulty primary control.	Replace primary control.
<i>Poor Fire</i>	Inspect flame for shape and uniformity or color	Unbalanced fire Excessive draft. Insufficient draft. Too little combustion air.	Replace nozzle with specified nozzle. Reduce draft setting. Increase draft. Increase combustion air.
<i>Heat Exchanger Restriction</i>	Take draft reading at flue box and read draft over the fire. Difference should not exceed $-.03''$.	Plugged heat exchanger.	Clean out heat exchanger.
<i>Burner Motor</i>	Burner motor trips on overload. Turn off power and rotate blower by hand to check for excessive drag.	Line voltage below 102V Faulty motor. Pump or blower overloading motor.	Call utility company. Replace motor. Replace blower or pump.

TROUBLE: INSUFFICIENT HEAT

SOURCE	PROCEDURE	CAUSES	REMEDY
<i>Circulator</i>	Check if circulator is operational.	Coupling worn or broken.	Replace coupling.
		Pump binding.	Replace pump.
		Circulator motor burned out.	Replace circulator motor.
		Wiring from operating control defective.	Repair wiring.
		Operating control defective.	Repair or replace operating control.
	Check if circulator is correct size.	Circulator too small.	Replace with proper circulator.
	Check if circulator is up to speed; check if voltage to circulator is sufficient.	Circulator defective.	Repair circulator.
		Insufficient voltage.	Call utility company.
<i>Thermostat</i>	Check thermostat settings.	Settings too low.	Increase setting.
	Check thermostat location.	Bad location due to heat build up.	Move thermostat to a better location.
	Check thermostat calibration.	Out of calibration.	Recalibrate.
<i>Flow Valve</i>	Check flow valve for sticking in partially closed position.	Flow valve not opening fully.	Clean or replace flow valve.
<i>Radiation</i>	Check for air in radiators.	Radiators airbound.	Bleed radiators.
	Check to see if radiators are sized properly.	Radiators inadequate.	Install adequate radiation.
<i>Boiler</i>	Determine structure heat load.	Boiler too small.	Additional heating capacity required.
<i>Piping</i>	Check to see if piping is sized properly.	Piping inadequate.	Install adequate piping.
<i>Tankless Coil</i>	Check usage of domestic hot water.	Demand too large.	Install flow regulator. Additional boiler capacity required.
<i>Heat Exchanger</i>	Check heat exchanger for soot or scale accumulation.	Insufficient heat transfer.	Clean heat exchanger.
<i>Burner</i>	Check pump pressure with pressure gauge.	Insufficient pump pressure.	Increase pressure to 140 psi.
<i>Nozzle</i>	Check nozzle for size and spray angle.	Wrong nozzle installed.	Install specified nozzle.
	Check nozzle for plugged orifice, scored surface.	Nozzle underfiring due to defective nozzle.	Replace nozzle.

TROUBLE: TOO MUCH HEAT

SOURCE	PROCEDURE	CAUSES	REMEDY
<i>Circulator</i>	Check to see if operating control is working properly.	Circulator does not stop running.	Repair operating control.
<i>Thermostat</i>	Check thermostat settings and calibration.	Thermostat set too high.	Reset thermostat.
		Thermostat defective.	Replace thermostat.
		Thermostat out of calibration.	Recalibrate.
<i>Flow Valve</i>	Check to see if flow valve is operating properly.	Flow valve dirty and stuck.	Clean flow valve.
		Flow valve defective.	Replace flow valve.

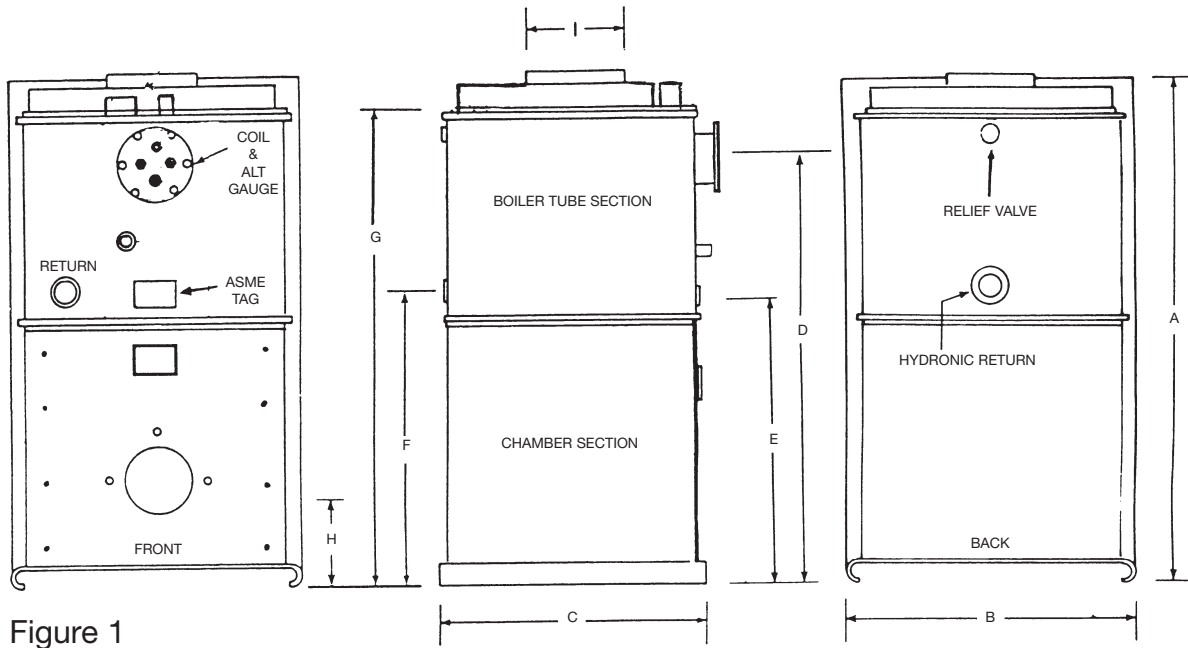

Figure 1

S Series Dimensions

A - Jacket Height	38 ^{1/2}
B - Jacket Width	21 ^{1/4}
C - Jacket Length	21 ^{1/4}
D - Coil Height	31 ^{1/2}
E - Hydronic Return Height	22
F - Alt. Hydronic Return	22
G - Hydronic Supply Height	36
H - Burner Opening From Floor	8 ^{3/4}
I - Flue Pipe Diameter	6

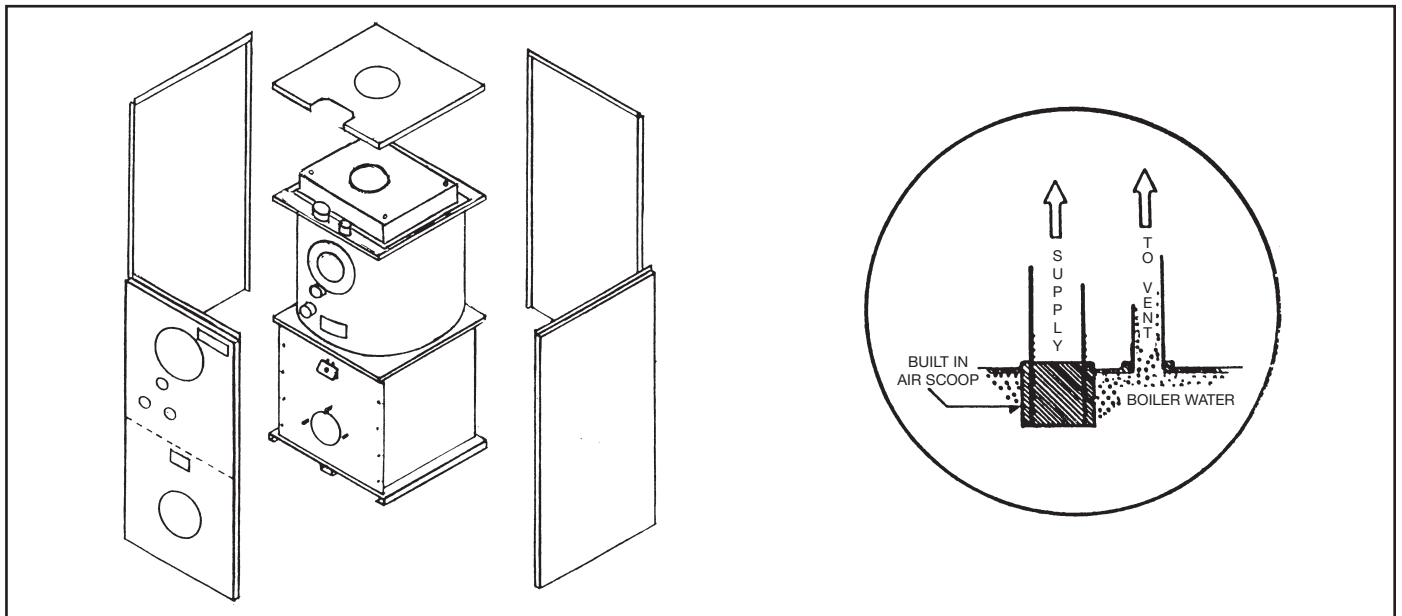

Figure 2. Jacket Assembly

Specifications

MODELS	S85	S100	S110	S125	S135	S150	STR-85	STR-100	STR-110
IBR Firing Rate G.P.H. (Max.)	.85	1.00	1.10	1.25	1.35	1.50	.85	1.00	1.10
IBR Input (BTU/HR)	119,000	140,000	154,000	175,00	189,000	210,000	119,000	140,000	154,000
IBR Heating Capacity (BTU/HR)*	100,000	117,000	129,000	148,000	159,000	174,000	101,000	121,000	133,000
IBR Net Rating (BTU/HR)	87,000	102,000	112,000	129,000	138,000	151,000	88,000	106,000	116,000
Chimney Size	8x8x15	8x8x15	8x8x15	8x8x815	8x8x15	8x8x15	8x8x15	8x8x15	8x8x15
Draft Over Fire (Negative)	-.02	-.02	-.02	-.02	-.02	-.02	-.02	-.02	-.02
Water Content (Gal.)	16	15-1/2	15	14	14	14	15	14	14
Domestic Coil Capacity** gpm	3 or 5	3 or 5	3 or 5	3 or 5	3 or 5	3 or 5	3 or 5	3 or 5	3 or 5
A - Jacket Height	38-1/2"	38-1/2"	38-1/2"	38-1/2"	38-1/2"	38-1/2"	38-1/2"	38-1/2"	38-1/2"
B - Jacket Width	21-1/4"	21-1/4"	21-1/4"	21-1/4"	21-1/4"	21-1/4"	21-1/4"	21-1/4"	21-1/4"
C - Coil Supply Height	31-1/2"	31-1/2"	31-1/2"	31-1/2"	31-1/2"	31-1/2"	31-1/2"	31-1/2"	31-1/2"
D - Hydronic Return Height	22"	22"	22"	22"	22"	22"	22"	22"	22"
E - Jacket Length	21-1/4"	21-1/4"	21-1/4"	21-1/4"	21-1/4"	21-1/4"	21-1/4"	21-1/4"	21-1/4"
F - Alt. Hydronic Return	22"	22"	22"	22"	22"	22"	22"	22"	22"
G - Hydronic Supply Height	36"	36"	36"	36"	36"	36"	36"	36"	36"
H - Flue Pipe Diameter	6"	6"	6"	6"	6"	6"	6"	6"	6"
I - Relief Valve Height	33-1/2"	33-1/2"	33-1/2"	33-1/2"	33-1/2"	33-1/2"	33-1/2"	33-1/2"	33-1/2"
Shipping Weight (Approx.)	320	325	330	345	350	360	330	360	360
Hydronic Supply Tapping	1-1/4"	1-1/4"	1-1/4"	1-1/4"	1-1/4"	1-1/4"	1-1/4"	1-1/4"	1-1/4"
Hydronic Return Tappings	2-1-1/4"	2-1-1/4"	2-1-1/4"	2-1-1/4"	2-1-1/4"	2-1-1/4"	2-1-1/4"	2-1-1/4"	2-1-1/4"
AFUE***	83.3	83.1	83.0	84.3	83.9	83.0	85.2	85.4	85.1

•Based on D.O.E. Test Procedures

••Coil capacity based on 5 min. draw. 5 min. waiting period.

***AFUE with vent damper - S85-110 2.5% higher, S125-150 1.4% higher

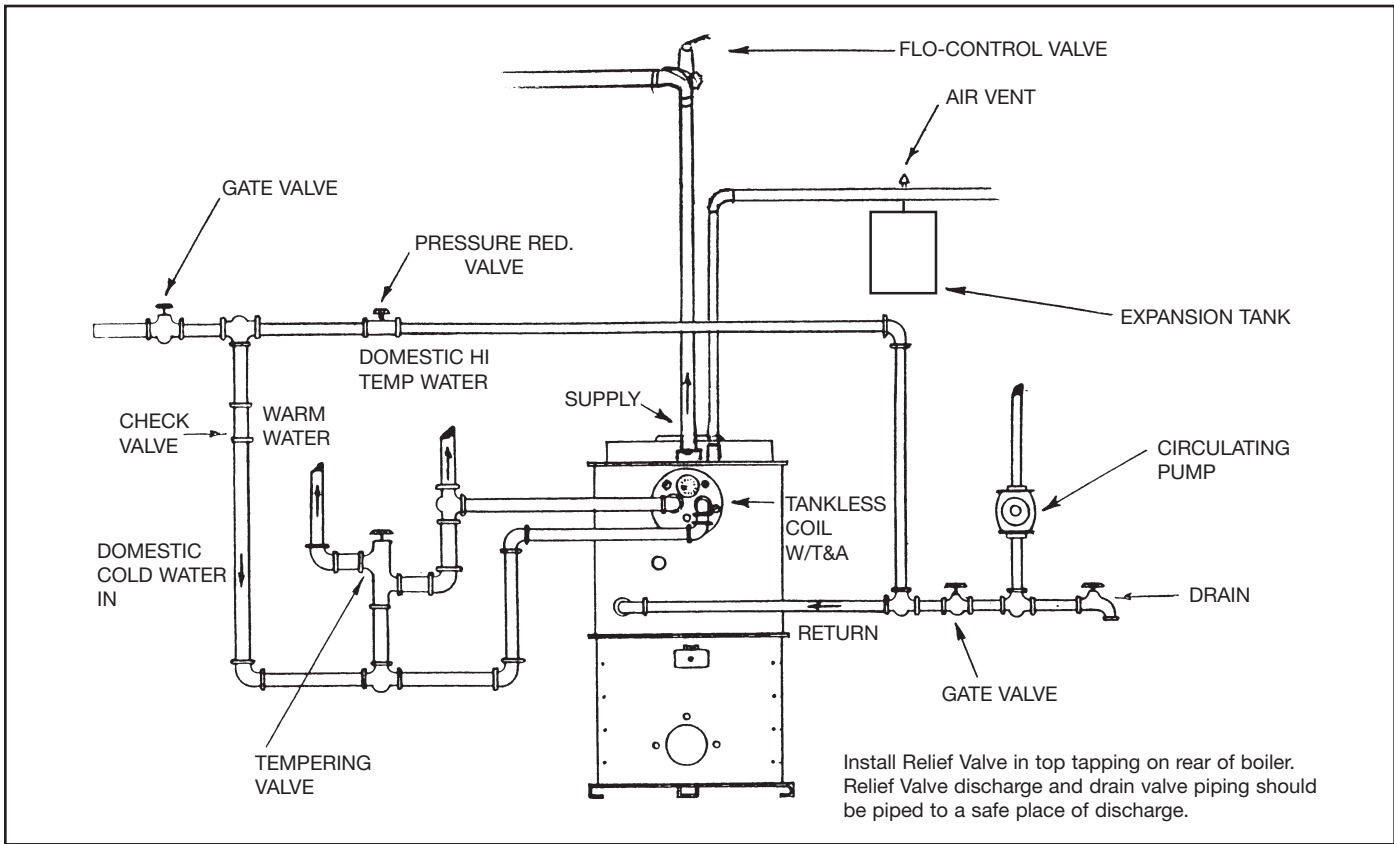
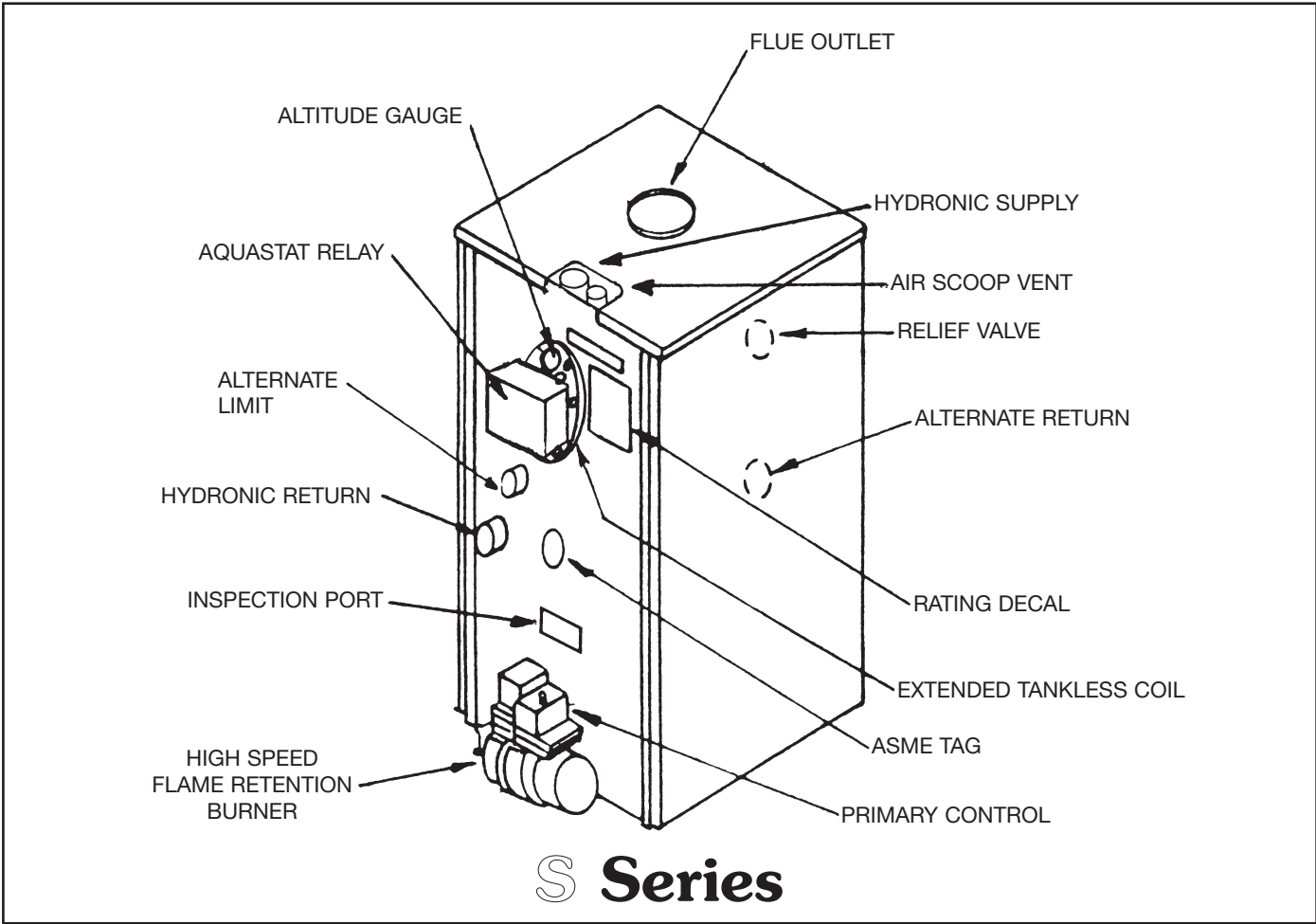
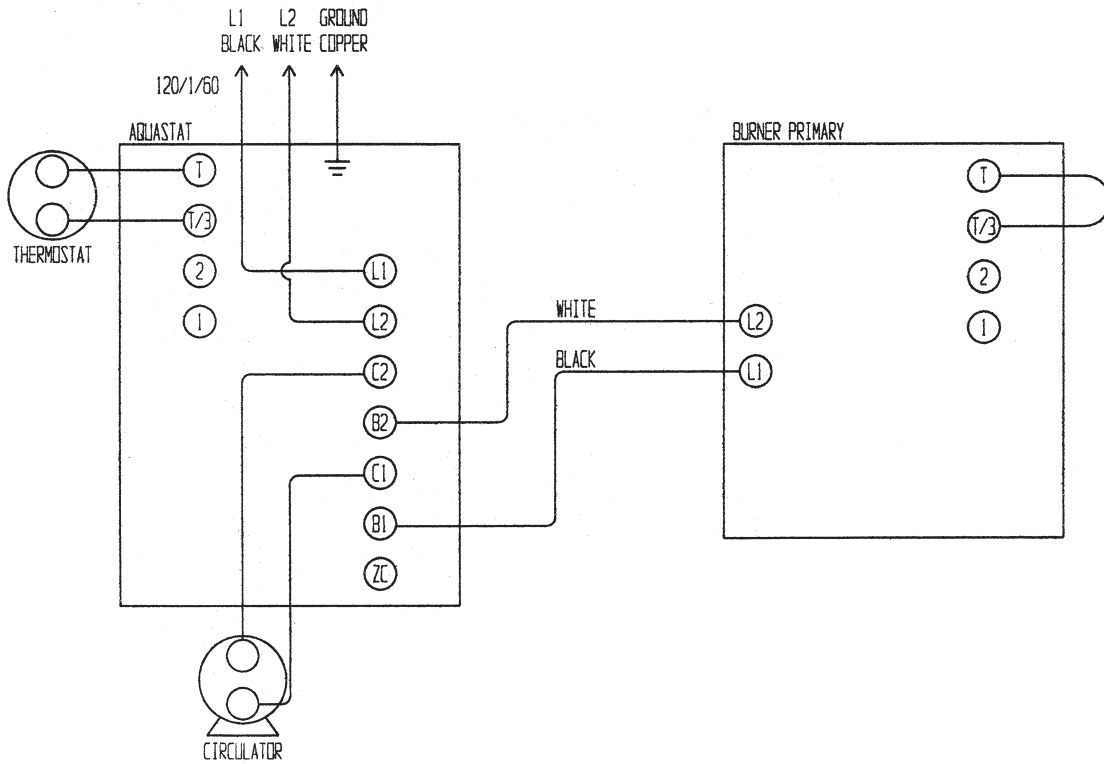
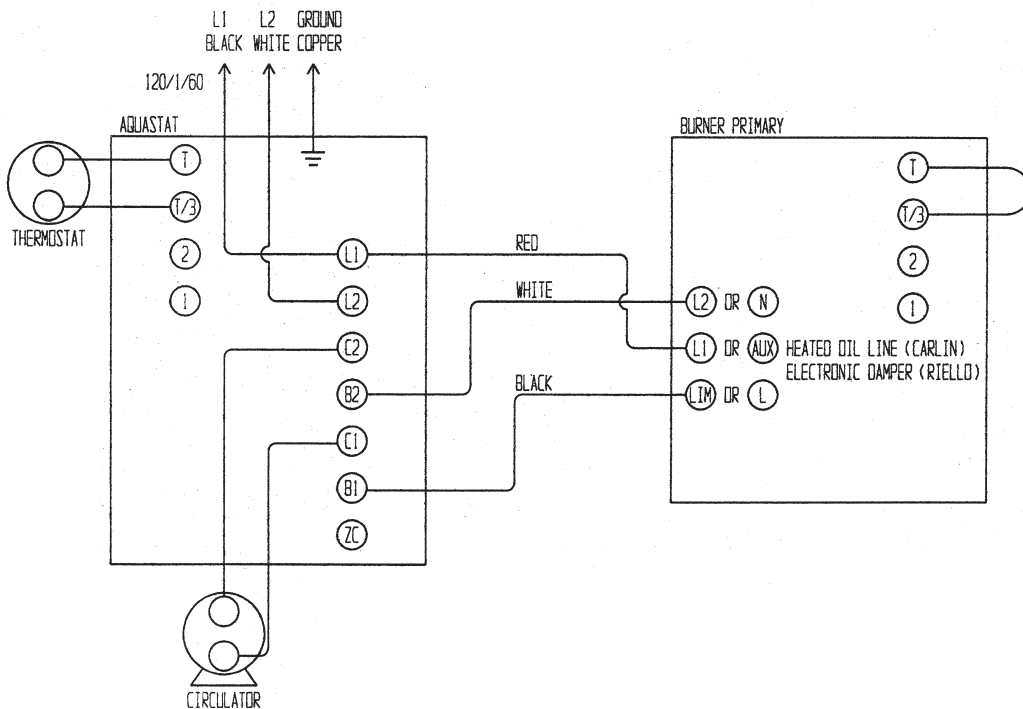

Figure 3. Boiler Piping

ELECTRICAL DIAGRAM FOR S SERIES BOILERS TO CONNECT BURNER TO AQUASTAT (APPLIES TO BECKETT CHIMNEY VENT BURNERS)



ELECTRICAL DIAGRAM FOR S SERIES BOILERS TO CONNECT BURNER TO AQUASTAT (APPLIES TO CARLIN CHIMNEY VENT AND RIELLO CHIMNEY VENT BURNERS)



INSTALLER/SERVICEMAN

Model Number	S-125	S-135	S-150
Burner Type	Riello	Riello	Riello
Burner Model	F5	F5	F5
Nozzle Type	1.00 60A	1.10 60A	1.25 60A
Pump Pressure PSI	150	150	150
Head/Pin Position	2.5	3.5	4.0
Air Band	N/A	N/A	N/A
Air Shutter	4.5	4.5	5.5
Draft Over Fire	-0.02"	-0.02"	-0.02"
Draft In Stack	-0.05"	-0.05"	-0.05"
CO ₂ Reading	10-11.5	10-11.5	10-11.5
Smoke Reading	ZERO	ZERO	ZERO

NOTICE

Above settings are approximate. Final adjustments to be made with proper test equipment. Be sure all oil lines are air free and the use of flare fittings is recommended. See installation/service manual for detailed information.

INSTALLER/SERVICEMAN

Model Number	S-125	S-135	S-150
Burner Type	Carlin	Carlin	Carlin
Burner Model	EZ-1	EZ-1	EZ-1
Nozzle Type	1.00 60A	1.10 60A	1.25 60A
Pump Pressure PSI	140	140	140
Head/Pin Position	110-125	135-150	135-150
Air Band	1.25	1.35	1.50
Air Shutter	N/A	N/A	N/A
Draft Over Fire	-0.02"	-0.02"	-0.02"
Draft In Stack	-0.05"	-0.05"	-0.05"
CO ₂ Reading	10-11.5	10-11.5	10-11.5
Smoke Reading	ZERO	ZERO	ZERO

NOTICE

Above settings are approximate. Final adjustments to be made with proper test equipment. Be sure all oil lines are air free and the use of flare fittings is recommended. See installation/service manual for detailed information.

INSTALLER/SERVICEMAN

Model Number	S-125	S-135	S-150
Burner Type	Beckett	Beckett	Beckett
Burner Model	AFG	AFG	AFG
Nozzle Type	1.00 80A	1.10 80A	1.25 80A
Pump Pressure PSI	140	140	140
Head/Pin Position	F-12	F-12	F-12
Air Band	CLOSED	1	2
Air Shutter	10	10	10
Draft Over Fire	-0.02"	-0.02"	-0.02"
Draft In Stack	-0.05"	-0.05"	-0.05"
CO ₂ Reading	10-11.5	10-11.5	10-11.5
Smoke Reading	ZERO	ZERO	ZERO

NOTICE

Above settings are approximate. Final adjustments to be made with proper test equipment. Be sure all oil lines are air free and the use of flare fittings is recommended. See installation/service manual for detailed information.

INSTALLER/SERVICEMAN

Model Number	S-85		
Burner Type	Beckett	Carlin	Riello
Burner Model	AFG*	EZ-1	F5
Nozzle Type	0.65 80B	0.65 60A	0.65 60A
Pump Pressure PSI	140	140	150
Head/Pin Position	F-3	85-100	1.5
Air Band	CLOSED	0.85	N/A
Air Shutter	10	N/A	1.75
Draft Over Fire	-0.02"	-0.02"	-0.02"
Draft In Stack	-0.05"	-0.05"	-0.05"
CO ₂ Reading	10-11.5	10-11.5	10-11.5
Smoke Reading	ZERO	ZERO	ZERO

*With AFG use low firing rate baffle

NOTICE

Above settings are approximate. Final adjustments to be made with proper test equipment. Be sure all oil lines are air free and the use of flare fittings is recommended. See installation/service manual for detailed information.

INSTALLER/SERVICEMAN

Model Number	S-100		
Burner Type	Beckett	Carlin	Riello
Burner Model	AFG	EZ-1	F5
Nozzle Type	0.75 80B	0.75 60A	0.75 60A
Pump Pressure PSI	140	140	150
Head/Pin Position	F-3	85-100	2.0
Air Band	CLOSED	1.00	N/A
Air Shutter	8	N/A	4
Draft Over Fire	-0.02"	-0.02"	-0.02"
Draft In Stack	-0.05"	-0.05"	-0.05"
CO ₂ Reading	10-11.5	10-11.5	10-11.5
Smoke Reading	ZERO	ZERO	ZERO

NOTICE

Above settings are approximate. Final adjustments to be made with proper test equipment. Be sure all oil lines are air free and the use of flare fittings is recommended. See installation/service manual for detailed information.

INSTALLER/SERVICEMAN

Model Number	S-110		
Burner Type	Beckett	Carlin	Riello
Burner Model	AFG	EZ-1	F5
Nozzle Type	.85 80B	0.85 60A	0.85 60A
Pump Pressure PSI	140	140	150
Head/Pin Position	F-3	110-125	2.5
Air Band	CLOSED	1.10	N/A
Air Shutter	10	N/A	4
Draft Over Fire	-0.02"	-0.02"	-0.02"
Draft In Stack	-0.05"	-0.05"	-0.05"
CO ₂ Reading	10-11.5	10-11.5	10-11.5
Smoke Reading	ZERO	ZERO	ZERO

NOTICE

Above settings are approximate. Final adjustments to be made with proper test equipment. Be sure all oil lines are air free and the use of flare fittings is recommended. See installation/service manual for detailed information.

STR Energy Star Product

INSTALLER/SERVICEMAN

Model Number	STR-85		
	Beckett	Carlin	Riello
Burner Type	AFG*	EZ-1	F5
Burner Model	AFG*	EZ-1	F5
Nozzle Type	0.65 80B	0.65 60A	0.65 60A
Pump Pressure PSI	140	140	150
Head/Pin Position	F-3	85-100	1.5
Air Band	CLOSED	0.85	N/A
Air Shutter	10	N/A	1.75
Draft Over Fire	-0.02"	-0.02"	-0.02"
Draft In Stack	-0.05"	-0.05"	-0.05"
CO ₂ Reading	10-11.5	10-11.5	10-11.5
Smoke Reading	ZERO	ZERO	ZERO

*With AFG use low firing rate baffle

NOTICE

Above settings are approximate. Final adjustments to be made with proper test equipment. Be sure all oil lines are air free and the use of flare fittings is recommended. See installation/service manual for detailed information.

INSTALLER/SERVICEMAN

Model Number	STR-100		
	Beckett	Carlin	Riello
Burner Type	AFG	EZ-1	F5
Burner Model	AFG	EZ-1	F5
Nozzle Type	0.75 80B	0.75 60A	0.75 60A
Pump Pressure PSI	140	140	150
Head/Pin Position	F-3	85-100	2.0
Air Band	CLOSED	1.00	N/A
Air Shutter	8	N/A	4
Draft Over Fire	-0.02"	-0.02"	-0.02"
Draft In Stack	-0.05"	-0.05"	-0.05"
CO ₂ Reading	10-11.5	10-11.5	10-11.5
Smoke Reading	ZERO	ZERO	ZERO

NOTICE

Above settings are approximate. Final adjustments to be made with proper test equipment. Be sure all oil lines are air free and the use of flare fittings is recommended. See installation/service manual for detailed information.

INSTALLER/SERVICEMAN

Model Number	STR-110		
	Beckett	Carlin	Riello
Burner Type	AFG	EZ-1	F5
Burner Model	AFG	EZ-1	F5
Nozzle Type	.85 80B	0.85 60A	0.85 60A
Pump Pressure PSI	140	140	150
Head/Pin Position	F-3	110-125	2.5
Air Band	CLOSED	1.10	N/A
Air Shutter	10	N/A	4
Draft Over Fire	-0.02"	-0.02"	-0.02"
Draft In Stack	-0.05"	-0.05"	-0.05"
CO ₂ Reading	10-11.5	10-11.5	10-11.5
Smoke Reading	ZERO	ZERO	ZERO

NOTICE

Above settings are approximate. Final adjustments to be made with proper test equipment. Be sure all oil lines are air free and the use of flare fittings is recommended. See installation/service manual for detailed information.

PARTS LIST

(Designate boiler and burner model numbers on all orders.)

Item No.	Description	Part No.
1	Carlin EZ1 Burner	542200
2	Riello 5F Burner 6" Tube w.Primary	541152
3	Beckett AGF Burner	540545
4	Solid State Electronic Transformer	675981
5	F-3 Burner Head (S-85/110 AFG)	675400
6	F-12 Burner Head (S-125/150 AFG)	675420
7	3-1/2" Static Plate (All AFG)	675931
8	Low Firing Rate Baffle (S-85/AFG)	675920
9	Suntech Single-Stage Fuel Pump	675300
10	Suntech Two-Stage Fuel Pump (Optional)	675310
11	007 Circulator Pump	535030
12	Primary Control L7184B	553018
13	Aquastat Control L7224C	552102
14	Relief Valve 3/4" (Male)	575020
15	Altitude Gauge 1/4"-2-1/2" Round	559560
16	Coil Gasket (TDR All)	481005
17	Blank Coil Plate with 3/4" Tapping (TDR)	229151
18	#35 Coil (TDR) w/Gasket - Cartoned	530243
19	#55 Coil (TDR) w/Gasket - Cartoned	530245
20	Replacement Soft Chamber Only	337350
21	Chamber Base Assembly (Complete with Metal Base)	221750
22	Chamber Base Front Only (Metal with Studs)	223080
23	Cast Iron Peep Door Assembly (with Test Plug)	815800
24	Spacer Block (Between Chamber & Base)	337352
25	Baffles (State Model & Amount)	229510
26	Nozzles Beckett AFG @ 140 PSI Pump Pressure	
	.65 - 80°B (S-85)	680102
	.75 - 80°B (S-100)	680117
	.85 - 80°B (S-110)	680127
	1.00 - 80°A (S-125)	680146
	1.10 - 80°A (S-135)	680156
	1.25 - 80°A (S-150)	680176
	.65 - 80°B (STR-85)	680102
	.75 - 80°B (STR-100)	680117
	.85 - 80°B (STR-110)	680127

S Series

Service Set-Up Records

	Initial Set Up 1	2	3	4	
1. Date					
2. Model Number					
3. Firing Rate					
4. Pump Pressure Set 140 PSI					
5. CO					
6. "O" Smoke					
7. Gross Stack°					
8. Draft Over Fire					
9. Replaced Filter Yes/No					
10. Replaced Nozzle Yes/No					
11. Clean Pump Filter Yes/No					
12. Inspect Coil Gasket					
13. Check for leaks @ plugs/fittings					
14. *Brush Clean Flue Tub Passages					
15. Vacuum Chamber/Flue Tubes					
16. Clean Blower Wheel					
17. Check/Set Electrodes					

*Soft fiber chamber...Exercise care to avoid damage.

EXPLANATION OF LOW FIRING RATE BAFFLE

The Beckett low firing rate baffle is a small metal plate. It is installed over the back of the blower wheel scroll, which is visible when the transformer is swung back.

The low firing rate baffle is used to partially restrict the flow of combustion air to the combustion head. When the baffle is placed in the stream of air going from the blower wheel to the head, it increases the load on the blower wheel. This reduces the CFM and increases the operating pressure.

At the lower firing rates the combustion head has an easier time controlling the reduced air supply. The result is better starts and running characteristics. Flame stability at start-up is improved due to higher blower operating pressure which tends to dampen flame pulsations. It also means less sensitive air shutter adjustments.

Another advantage is that the inlet air controls must now be opened more to overcome the added resistance of the baffle. This means that the openings are less prone to restriction due to buildup of dust, lint or pet hair.

The baffle is used only on the model S-85.

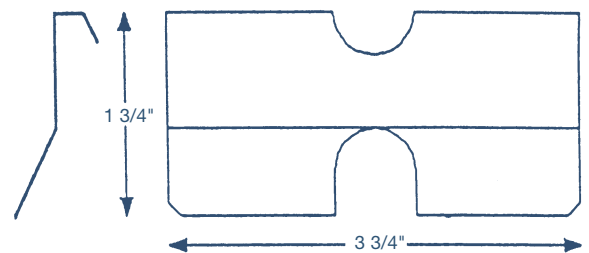

figure 1

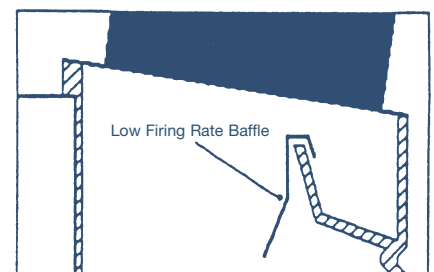

figure 2