

TDX Series

Installation Operation Maintenance Manual



www.thermodynamicsboiler.com

Thermo-Dynamics Boiler Company

ROUTE 61 • P.O. BOX 325 • SCHUYLKILL HAVEN, PA 17972
(570) 385-0731 FAX (570) 385-5304

Service Policy

Congratulations on the purchase of your boiler. Here at Thermo-Dynamics Boiler Company we pride ourselves on the design and construction of our product. Our intent is to furnish you with a high quality appliance that will provide you and your family with years of trouble free service.

In order to maintain peak performance of your boiler, it is recommended that the burner/boiler be serviced annually, preferably prior to the onset of the winter heating season. Servicing of your appliance must be performed by a qualified heating technician. You should utilize a qualified heating technician familiar with your installation to manage your boiler and perform periodic maintenance. Proper care and maintenance of your boiler will allow you to enjoy the benefits of your new purchase as well as extend its long useful life.

In the event that your serviceman encounters difficulty with the boiler, he/she shall contact the distributor from which the product was purchased. The distributor shall, in turn, contact the Thermo-Dynamics sales representative for your area. By adhering to this protocol, Thermo-Dynamics wishes to provide you with responsive and unparalleled service. We realize the importance that our product means to you and your family and our goal is to get your boiler up and running as quickly as possible.

Thank you for purchasing the Thermo-Dynamics boiler. Again, it is our intent to provide you with a high quality trouble free product that will be part of your family for many years to come. Please consider Thermo-Dynamics Boiler Company in the future for all of your home heating needs.

Boiler Installation and Operating Manual

Contents

Subject	Page
Read This First	2
Specifications	4
Installation	4
Operational Sequence	7
Start-Up	8

Appendices

Troubleshooting Guide	A	14
Dimensions	B	16
Piping Diagrams	C	17
Wiring Diagrams	D	18
Installer/Service Man Labels	E	20
Burner Service Set Up Records		22
Installation and Service Check List	Back Cover	

Read This First. *This manual applies to the four versions of the boiler, boiler with domestic hot water coil, boiler less domestic hot water coil, high efficiency boiler with domestic hot water coil and high efficiency boiler less domestic hot water coil.*

1. *Installer must be a trained, experienced technician and should read all instructions before installation.*
2. *Inspect the boiler, jacket and all components to be sure damage has not occurred in shipment. If damage is evident a claim must be filed with the freight carrier who transported the boiler from the factory to the distributor where it was purchased. Do not install the boiler. Contact your distributor.*
3. *Disconnect power supply before connecting wiring.*
4. *Refer to local codes for oil burning equipment, for recommended installation practice. You will need to be familiar with NFPA International Standard 31, "Standard for the Installation of Oil Burning Equipment".*
5. *A complete heat loss calculation is necessary to choose the proper size unit to install. The boiler should be sized to within 25% of the actual heat loss of the structure. Over sizing will result in short cycling and inefficient operation.*
6. *When moving the boiler, do not push against the jacket or burner. Damage will result.*
7. *If the boiler is vented to a chimney, be certain the chimney is clean and free of obstructions. The chimney must be masonry with tile lining or metal insulated with a stainless steel surface. The Chimney must be properly sized. Draft requirements are essential for safe and proper operation of the boiler.*

CAUTION: *Condensing boilers must be installed with an approved venting device as described in 8. below or to a chimney lined with a stainless steel liner.*

8. *If the boiler is connected to a venting device, make sure that it is listed by a recognized testing service. Follow the venting device manufacturer's installation instructions. Verify that the venting device installation complies with the recommendations of the manufacturer and local and state codes.*

9. *Conduct a thorough checkout when installation is complete. Check for indications of leaks and make sure that no material is left adjacent to the boiler.*
10. *The use of low sulfur No. 2 heating oil is highly recommended.*
11. *The following definitions apply to potential hazards noted in this manual.*

DANGER: *Indicates a hazardous situation which if not avoided will result in death or serious injury.*

WARNING: *Indicates a hazardous situation which if not avoided could result in death or serious injury.*

CAUTION: *Indicates a hazardous situation which if not avoided, may result in a minor injury. It may also warn against unsafe practices that may result in minor injury or damage to equipment.*

NOTICE: *Indicates that special attention to information is required. Not related to personal injury or property damage.*

12. *Modifications, substitutions or removal of equipment supplied or specified may result in property damage, personal injury or loss of life.*
13. *Condensate from the condensate drain at the bottom of the secondary heat exchanger must be routed to a condensate neutralizing tube such as the JJM Boiler Works JM2 or other device which may then be routed to a drain.*

CAUTION: *The condensate neutralizing device must be changed annually or in accordance with the manufacturer's instructions.*

Specifications

Model	-90	-100	-110
Input BTU/HR	126,000	140,000	154,000
Heat Capacity BTU/HR	110,000	121,000	132,000
Net Output BTU/HR	95,000	105,000	115,000
Firing Rate GPH	0.90	1.00	1.10
Supply	1 1/4"	1 1/4"	1 1/4"
Return	1 1/4"	1 1/4"	1 1/4"
Coil Capacity (WC Model)	5 GPM	5 GPM	5 GPM
Steady State	87.0	86.5	86.0
AFUE	87.0	86.5	86.0
AFUE Condensing Model	90.2	89.6	89.2
Burner Model	Carlin EZ-1 PRO	Carlin EZ-1 PRO	Carlin EZ-1 PRO
Burner Model	Beckett NX	Beckett NX	Beckett NX

A. Installation Instructions

- 1) Place the boiler on a level floor, preferably raised and as close to the chimney as possible. Refer to the installers label to determine if the boiler may be installed on combustible flooring or if non-combustible flooring is required. The minimum clearances for installation are shown below. Reduced clearance installations must follow NFPA-31 guidelines. If the boiler is a Knock Down (not packaged for ease of installation), install the jacket in accordance with the directions provided in the jacket package, prior to piping.

Standard Clearances	
Front	24"
Sides	6"
Rear	12"
Top	18"
Chimney Connector	18"
Floor	Non-Combustible

NOTICE: It is particularly important to install the high efficiency version of this boiler raised approximately 8"-10" off of the floor to allow for installation of the condensate drain.

- 2) Install the boiler piping. For location of piping refer to the Installation Drawing.

DANGER: Boilers with tankless coils must be piped in accordance with the piping diagram including installation of a tempering or mixing valve. Domestic hot water temperatures exceeding 125°F will cause severe burns instantly or death by scalding.

WARNING: Relief valve discharges and drain valve piping must be piped to a safe place of discharge.

NOTICE: These Boilers are provided with a built-in air scoop feature. This feature allows quiet, air free operation of the hot water system by eliminating air pockets without installation of air scoops. The supply line tapping in the top of the boiler extends approximately 1 inch below

the top of the boiler, allowing only air-free water to enter the heating system supply. Any air trapped in the top of the boiler is purged through the 3/4" vent tapping. The 3/4" vent tapping should be connected to an automatic float vent, a manual vent or piped to a conventional expansion tank.

- 3) Packaged boilers are shipped with the burner and aquastat installed and wired. See the basic wiring Diagram for wiring schematic. See component manufacturer's manual for wiring instructions.

Condensing boilers are shipped with secondary heat exchanger isolation valves and piping installed. A separate relief valve for the secondary heat exchanger is installed and piped inside of the rear jacket.

- 4) An expansion tank, not provided, must be matched to the system and installed in accordance with the manufacturer's instructions. Do not undersize the expansion tank. An automatic feed and pressure reducing valve, not provided, should be installed in the water inlet line to keep the entire system from falling below the pressure setting of the valve (about 12 psi) See the feed valve suppliers instructions for maximum allowed water supply pressure and requirements for pressure reducers. For piping and wiring of other system components see the manufacturer's installation manuals.
- 5 The tank-less water heater may be piped as shown in the Installation Drawing. A mixing valve (tempering valve), not supplied, must be used to reduce the water temperature at kitchen or bathroom taps. High temperature water for a dishwasher may be obtained by piping as shown in the Installation Drawing. The nuts that secure the tank-less coil flange should be tightened before the boiler is filled with water, after initial firing and once a year during the annual maintenance.

CAUTION: Deterioration due to coil gasket leaks will void the warranty.

- 6) a. Chimney Vent Applications. Connect boiler flue outlet to chimney using galvanized smoke pipe. The flue pipe should be pitched upward at least 1/4" per foot of run. Refer to the boiler specifications for proper size flue pipe for your model boiler. Use only elbows and straight sections. Tees may be used in a straight section in conjunction with a barometric draft regulator however they must not be used for a 90° turn. Each joint should be securely fastened with sheet metal screws. The flue pipe must not be inserted beyond the inside wall of the chimney. Install barometric draft regulator in the horizontal or vertical section of the flue pipe. The draft regulator should be installed in accordance with the manufacturer's instructions. Set the draft to in the stack as specified in the boiler specifications and on the Installer/Service Man Label on the boiler jacket. The flue gas exit of the venting system should be at designed with clearances in accordance with NFPA 31. A chimney must be at least 3 feet above the highest point where it passes through the roof and at least 2 feet higher than any portion of a building within 10 feet of the venting system. The horizontal length of a chimney connector should not exceed 10 feet unless a draft booster is used. Where the possibility of down drafts exist, install a listed vent cap.

CAUTION: Condensing boilers may only be installed to vent to a stainless steel chimney liner or to a direct vent device.

- b. Direct Vent Applications. Follow the instructions provided with the Double Wall Direct Vent Kit for installation, operation and maintenance.

CAUTION: External vent surfaces are hot.

NOTICE: Use only the venting system components supplied with the kit.

NOTICE: Surface discoloration of the building may occur due to improper burner/boiler adjustment. Manufacturer will not accept any liability for such discoloration.

- 7) The boiler room must be well ventilated to allow sufficient make-up air to support combustion. Lack of adequate combustion air may result in erratic operation of the burner, noisy combustion or fuel odors. Remember your need for outside air will be greatly increased if you have a vented dryer in the basement or other venting fans in the home. Boilers located in confined spaces shall be provided with two permanent openings, one near the top and one near the bottom of the enclosure. Each opening shall have a free area of not less than one square inch per 1000 BTU per hour input rating of the boiler, freely communicating with interior areas having adequate infiltration from the outside.
- 8) Fill boiler and system with water. Be sure entire system has been purged of air and the desired pressure is obtained. Leak-check the boiler and piping system by turning off the make-up water supply and observing the boiler pressure gage. A loss of pressure indicates a system leak that must be repaired prior to operating the boiler. For condensing boilers make sure that secondary heat exchanger isolation valves are open during filling and operation.

CAUTION: Leaving the secondary heat exchanger isolation valves shut during operation may result in damage to the secondary heat exchanger and discharge of hot water or steam through the secondary heat exchanger relief valve.

- 9) Remove the nozzle line assembly and check that the correct nozzle is installed for the desired firing rate. Check that burner settings are correct for the nozzle that is installed. See the Installer/Serviceman Label.
- 10) Connect burner to fuel supply. Refer to fuel unit manufacturer literature for piping, connections, lift and tank installation. If such information is unavailable use the following guide lines.

FUEL UNITS/FUEL LINES

Fuel supply "level with" or "above" burner: A single stage fuel unit connected to the fuel supply with a single supply line is the most common type of installation for these conditions. Manual venting of the fuel unit is usually required on initial start-up. Failure to vent air could result in an air lock/oil starvation condition. (One pipe)

Fuel supply below the level of burner: Use a single stage fuel unit in lift conditions of up to 10 ft., and a two stage fuel unit when the lift exceeds 10 ft. Both conditions require the use of a return line which purges the fuel unit of air returning it to the fuel tank. The "by-pass" plug must be inserted into the fuel unit when installing a return line. (Two pipe)

Fuel line installation: Continuous lengths of heavy wall copper tubing are recommended and should be installed under the floor when possible. Always use flare fittings. Always install fittings in accessible locations. Never use teflon tape on any fuel fitting. Use of teflon will void any warranty. Fuel lines should not run against the appliance or the ceiling joists.

Fuel line valve and filter: Install two high quality shutoff valves in accessible locations on the oil supply line. Locate one close to the tank and the other close to the burner ahead of the filter. Some filters come with built-in shutoff valves. Install a generous capacity filter inside the building between the fuel tank shutoff valve and the burner locating both the filter and the valve close to the burner for ease of servicing.

CAUTION: All oil feed lines to burners must be air tight. Use only flare fittings when assembling oil lines since the slightest air leak, caused by loose fittings, bad gaskets or any other reason, can cause a foaming oil stream which will cause any of the following conditions:

- a) Intermittent firing, causing safety shutdown
- b) Poor starts
- c) Smokey starts
- d) Continual sooting of boiler and burner parts including the cad cell
- e) Reduced firing rate, inefficient operation and erratic fire pattern
- f) A dangerous combustion condition, allowing the firebox to fill with a lean mixture (too much air in the oil stream) which could cause a delay in ignition of the fuel mixture until the danger point has been reached.

Suction Vacuum Test. A fuel pump suction vacuum test should be performed. See the fuel pump manufacturers literature for details. The suction vacuum must be limited to ensure that there is adequate pump lift. This problem becomes proportionately larger with underground tanks. If the following procedures are followed, burner related problems will be minimized:

- a) Connect vacuum gauge to fuel pump. Suction vacuum must not exceed 10 inches of mercury for single stage pumps and 15 inches for two stage pumps. It is preferable to stay below these limitations.
 - b) When the suction line is tight and properly installed the pump will hold its vacuum for a minimum of 60 minutes after shutdown.
 - c) Installation of a check valve in the suction line of a two pipe system is advisable under all circumstances. Be sure the check valve fittings are airtight.
- 11) Connect the electric supply to the boiler as indicated on the wiring diagram. The wiring must be installed in accordance with the National Electrical Code and any other state and local codes and the following requirements.
- a) Internal wiring is completed at the factory on packaged boilers. External wiring must conform with the National Electric Code and local codes.
 - b) Field connections should be protected with a 15 amp fuse.
 - c) A separate, fused disconnect switch should be installed and located near the unit so that power can be shut-off for servicing, unless already equipped.
 - d) Install the room thermostat (not provided) on an inside wall away from cold drafts, windows or heat from fireplaces, appliances or sunlight. Set the heat anticipator in accordance with the manufacturer's instructions. Connect the thermostat leads to the "TT" terminals on the circulator control.

C. Operational Sequence

- 1) WC models equipped with tankless coil are equipped with a combination aquastat control which has high and low limits to be set at 180° F and 160° F respectively by the installer. These settings are nominal and may be adjusted for the particular installation conditions. A 20° F difference between high and low limit is recommended. The control prioritizes domestic hot water heating as explained below.
 - a) When room temperature falls below thermostat setting, thermostat calls for heat starting the burner and circulating pump. The burner and pump continue to operate until room heating requirements are satisfied (thermostat setting is reached), or until boiler water temperature reaches the high limit control temperature setting. If the high limit control temperature setting is reached, the burner shuts off and the circulating pump continues to operate until the room heating requirements are satisfied. If the thermo-

stat continues to call for heat after the boiler water temperature has dropped to approximately 10 degrees below the temperature setting of the high limit control, the oil burner will start again and the circulating pump will continue to run.

- b) The boiler water temperature is normally maintained at 160deg F around the tankless coil by the operating control so that an abundance of hot water is available. If the boiler water temperature should fall approximately 10 deg below the operation control low limit setting, the oil burner will be started by the control. The heating circuit circulator will not be energized unless there is a call for heat and until the boiler water temperature is above the low limit setpoint. (See High Efficiency Boiler with Domestic Coil Addendum for more details.) The burner will run until the operating control setting is satisfied. If there is no call for heat, the burner will turn off at the low limit set-point. The operating control has an adjustable low limit differential setting. The low limit differential setting determines how high the boiler temperature must rise before the burner turns off and or the circulator comes on if the thermostat calls for heat. The differential is measured from 10 deg F below the low limit. See control manufacturer's literature included in the data package for detailed wiring, operating and safety instructions.
 - c) The boiler water temperature is normally maintained at 160deg F around the tankless coil by the operating control so that an abundance of hot water is available. If the boiler water temperature should fall approximately 10 deg below the operation control low limit setting, the oil burner will be started by the control. The heating circuit circulator will not be energized. The boiler control is set at ___ and will energize the boiler circulator to circulate water through the boiler and the secondary heat exchanger. Circulating water through the boiler and secondary heat exchanger protects the system from possible hot spots in the secondary heat exchanger when there is no call for heat. The burner will run until the operating control setting is satisfied. The boiler circulator will run until the boiler control set point, ___ is reached. The operating control has an adjustable low limit differential setting. The low limit differential setting determines how high the boiler temperature must rise before the burner turns off and or the circulator comes on if the thermostat calls for heat. The differential is measured from 10 deg F below the low limit. See control manufacturer's literature included in the data package for detailed wiring, operating and safety instructions.
 - d) Adjusting the low limit differential to higher values will provide priority to heating domestic hot water over a greater range of boiler temperature. (Maximum of approximately 25°F differential measured from 10°F below the low limit setting.)
- 2) Boilers that do not have a tankless coil and are equipped with a high limit aquastat must be used with bypass control which should be set at 180°F by the installer. This setting is nominal and may be adjusted for the particular installation conditions. A bypass is not required for high efficiency condensing boilers.
- a) When room temperature falls below thermostat setting, thermostat calls for heat starting the burner and circulating pump. The burner and pump continue to operate until room heating requirements are satisfied (thermostat setting is reached), or until boiler water temperature reaches the high limit control temperature setting. If the high limit control temperature setting is reached, the burner shuts off and the circulating pump continues to operate until the room heating requirements are satisfied. If the thermostat continues to call for heat after the boiler water temperature has dropped to approximately 15 degrees below the temperature setting of the high limit control, the oil burner will start again and the circulating pump will continue to run.

- b) The boiler water temperature need not be maintained at a 160°F low limit setting since there is no domestic hot water load to protect. See control manufacturers literature included in the data package for detailed wiring, operating and safety instructions.
 - c) Boilers without Tankless Coils may be equipped with a combination aquastat that has a high and low limit setting. The high limit control is set at 180°F and the low limit is set based on the application. If the boiler is used with an indirect hot water heater for domestic hot water, the low limit is set at 160°F to support the operation of the indirect hot water heater. If the an indirect hot water heater is not used, the low limit may be set between 120°F and 140°F to provide protection against condensation in the boiler. The settings are nominal and many be adjusted for the particular installation conditions.
- 3) A cadmium sulfide flame scanner (cad cell) and relay are provided with the oil burner. The cad cell will stop the oil burner within a predetermined number of seconds if the fuel fails to ignite or if the flame goes out during operation. The oil burner will remain off until the red reset button on the relay has been pushed. Reset must never be pressed more than once during a single flame failure.

D. Start-Up and Check-Out Procedure

CAUTION : Only a trained, experienced serviceman should attempt the checkout procedure outlined below. You should read to the burner manual provided with this manual for specific instructions and set points.

- 1) Confirm that electrical power to the boiler is off. The fuel tank must be filled with No. 2 heating oil. Low Sulfur fuel is preferred.
- 2) Check electrode settings, nozzle size and air setting. Electrode settings are shown in the burner manual provided along with this manual. Burner settings are listed on the Service Man's Label attached to the boiler and on the Specifications provided along with this manual.
- 3) Set thermostats substantially above room temperature.
- 4) Open all shut-off valves in the fuel supply line to the burner.
- 5) Install pressure gauge in the port provided on the fuel pump. Attach a length of 1/4" O.D. clear plastic tubing to the end of the bleed plug.
- 6) Turn on power to the boiler. If burner does not start immediately reset manual overload switches and control. See control manual for reset instructions.
- 7) On one pipe systems bleed the fuel pump as soon as burner motor starts. To bleed the pump, loosen plug while holding an empty container under the tubing installed in step 6 to catch all of the expelled fuel. Bleed for at least 15 seconds after the fuel stream is free of all air. If air is still evident in the bleed line you must check the oil lines, all fittings, filters and any other connections for tightness. Kinks in the fuel lines will create undue high vacuum therefore they must be eliminated. When you are sure all air has been eliminated then close the bleed valve. Ignition should be instantaneous following the closing of this valve. If it is not, proceed to the trouble shooting guide to determine why the fuel did not ignite.
- 8) Be sure the fuel pump discharge pressure is adjusted to the pressure listed on the Installer/ Service Man Label. If it is not, refer to the burner manufacturer's instruction sheet for pressure adjustment procedure.

FINAL ADJUSTMENTS OF THE BURNER MUST BE MADE USING PROPER COMBUSTION TEST EQUIPMENT. Combustion test equipment required for proper burner adjustment:

- a) CO₂ Analyzer
- b) Draft Gauge
- c) Oil Pressure Gauge 0-200 PSI
- d) Stack Thermometer
- e) Smoke Test Gun
- f) Vacuum Gauge 0-30 in. of Hg

Notice: Read the burner manufacturer's instructions supplied with this manual to set combustion. The burner instructions contain special instructions that may apply to the model supplied with your boiler including how special features may affect the set-up procedure.

- 9) Burner Adjustments. Allow the burner to operate steadily for 5 to 15 minutes. Check burner settings shown on the Installer/Service Man Label and make the following adjustments.
 - a) Punch or drill a 1/4" hole in the flue pipe between the boiler and the barometric draft regulator. All test readings should be taken from this point.
 - b) Take a draft reading from the flue pipe sampling hole. Adjust the draft in the stack, using the barometric draft regulator, to the value shown on the Installer/Service Man Label. In tall chimneys a second draft regulator may be required in the flue pipe to regulate draft under high draft conditions.
 - c) Remove the draft port plug over the fire and take a draft reading from the draft port. Compare the readings with those on the INSTALLER/SERVICEMAN label. Refer to the trouble shooting procedure if the draft over the fire reading is not correct. Reinstall the draft port plug after all readings have been taken.
 - d) Follow the burner manufacturer's instructions to adjust the air supply until a trace of smoke is recorded. At the trace of smoke level, measure the CO₂. This is the reference point for all further adjustments.
 - e) Increase the air supply to reduce the CO₂ about 1-1/2% to 2% from the reference point. A zero smoke reading should result. If this adjustment can not be obtained, refer to the Trouble Shooting section of this manual.
 - f) When combustion is set, follow the burner manufacturer's instructions to lock or tighten adjustment mechanisms as required.
- 10) Check operation of the cad cell relay by removing one cad cell wire from external terminal during the flame cycle. The relay should cut the burner off in approximately 15 sec.
- 11) Direct Vent Applications. The burner control for direct vent applications is provided with a post-purge feature to keep the burner fan operating after the flame is off. The post purge cycle time is 120 seconds. See the burner manufacturer's operating instructions for more information on the post purge settings.

E. Servicing the Boiler/Burner Unit:

- 1) Burner Components: If replacement of burner parts is necessary, always use parts recommended by the manufacturer. Specify part number and description when ordering.
- 2) Electrode settings are important for reliable ignition of the fuel. Check to be sure the settings are in accordance with the instructions provided in the burner manual.
- 3) Nozzles: The nozzle specifications listed in the manual are the result of years of exhaustive engineering testing. Use extreme care in handling nozzles to avoid scratches or dirt that could cause leaks or affect the fuel spray pattern.

CAUTION: Any nozzle replacement should be of the exact type as listed in the specifications.

- 4) Fan and blower housing should be kept clean of dirt and lint. If heating unit is located near an unvented dryer, special care must be taken so that lint does not clog the burner air inlets.
- 5) Replace the fuel filter cartridge annually.
- 6) Check all water connections and plugs for evidence of leaks. Check for leaks by shutting the make-up water supply valve. If boiler pressure decreases, it is evidence of a leak which must be repaired.
- 7) Cleaning the Boiler: Cleaning should be done only by a trained, experienced serviceman.

DANGER: Before cleaning turn off all power to the boiler. Failure to turn off power could result in firing the boiler when it is open.

- a) Remove the burner cover by lifting up to disengage the fasteners and out to remove the cover. Remove the boiler front cover and rear cover by lifting up and out.
- b) Disconnect the control wires from the aquastat control to the burner.
- c) Remove the brass nuts that secure the hinged burner door and carefully open the door.
- d) Remove the rear cover on the flue box. For condensing boilers remove the rear cover of the secondary heat exchanger box. Remove the rear baffle piece by lifting up and pulling out. Clean the secondary coil using a mild solution of detergent and water or Simple Green cleaner. Rinse with water.
- e) Remove baffles from the units and clean them. Brush all tubes and the furnace tube with a #2 soft flue brush. For condensing boilers remove the two cleaning access panels on either side of the secondary heat exchanger box to allow access for vacuuming the residue from tubes. Before replacing the rear baffle piece and cover, make sure that the drain is clear. Replace all covers.
- f) Inspect the burner head. Remove any accumulation on the burner. Inspect and follow burner manufacturer's recommendations for cleaning and maintenance.
- g) Check all refractory and gaskets for resilience and continuity. Replace damaged parts prior to re-assembling the unit.

- h) Reassemble the boiler. For condensing boilers: Reinstall the secondary heat exchanger coil and connect the flanges to the inlet and outlet. Open the isolation valves, pressurize the system and check for leaks.
- 9) For condensing boilers replace the condensate neutralizing device annually following the manufacturers instructions.

F. Changing the Burner Door Hinge Location.

The side that the hinge is located on may be changed as follows.

- 1) Turn power off to the burner.

DANGER: Failure to turn off power to the burner during maintenance may result in serious injury or death.

- 2) Remove the burner cover by lifting it up, out and away from the burner. Remove the front boiler cover by lifting up, out and away from the burner.
- 3) Disconnect the burner power cord.
- 4) Disconnect the fuel supply line to the burner.
- 5) Remove the burner from the burner flange and set the burner to the side.
- 6) Remove two brass nuts that hold the door bracket to the boiler. Remove two brass nuts that hold the door bracket to the door. Remove the two brass nuts that hold the hinge the door. Set the door to the side.
- 7) Remove the two brass nuts that hold the hinge to the boiler, move the hinge to the other side and attach it to the boiler using two brass nuts. Do not tighten the nuts fully. The thick side of the hinge is attached to the boiler. The hinge pin is on the outside.
- 8) Attach the door bracket to the door using two brass nuts. Swing the door to make sure that it is free and that the door bracket fits over the boiler studs on the other side. Make final adjustments and tighten all nuts.
- 9) Close the door and attach the bracket to the boiler using two brass nuts. Do not tighten completely.
- 10) Install the burner. Remove the two nuts that hold the door flange to the boiler. Check that the door swings free. Adjust as required. Install and tighten door flange nuts.
11. Attach fuel supply line and burner cord to burner.

Follow start-up procedure in this manual. Check for combustion gas leaks around the door gasket and repair prior to operation.

Trouble Shooting Guide

Burner Will Not Start

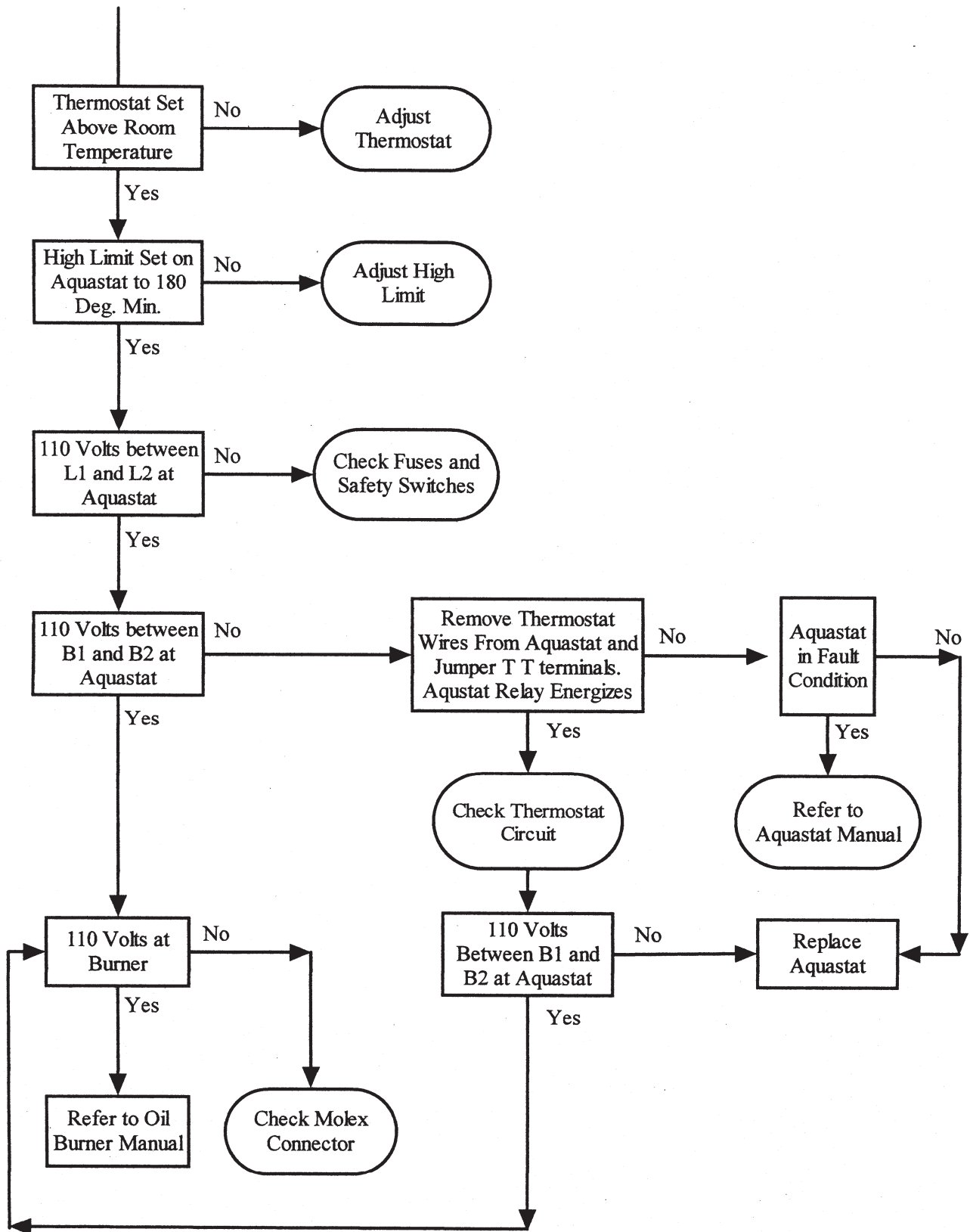

Appendix A-1

Burner Goes Off On Safety

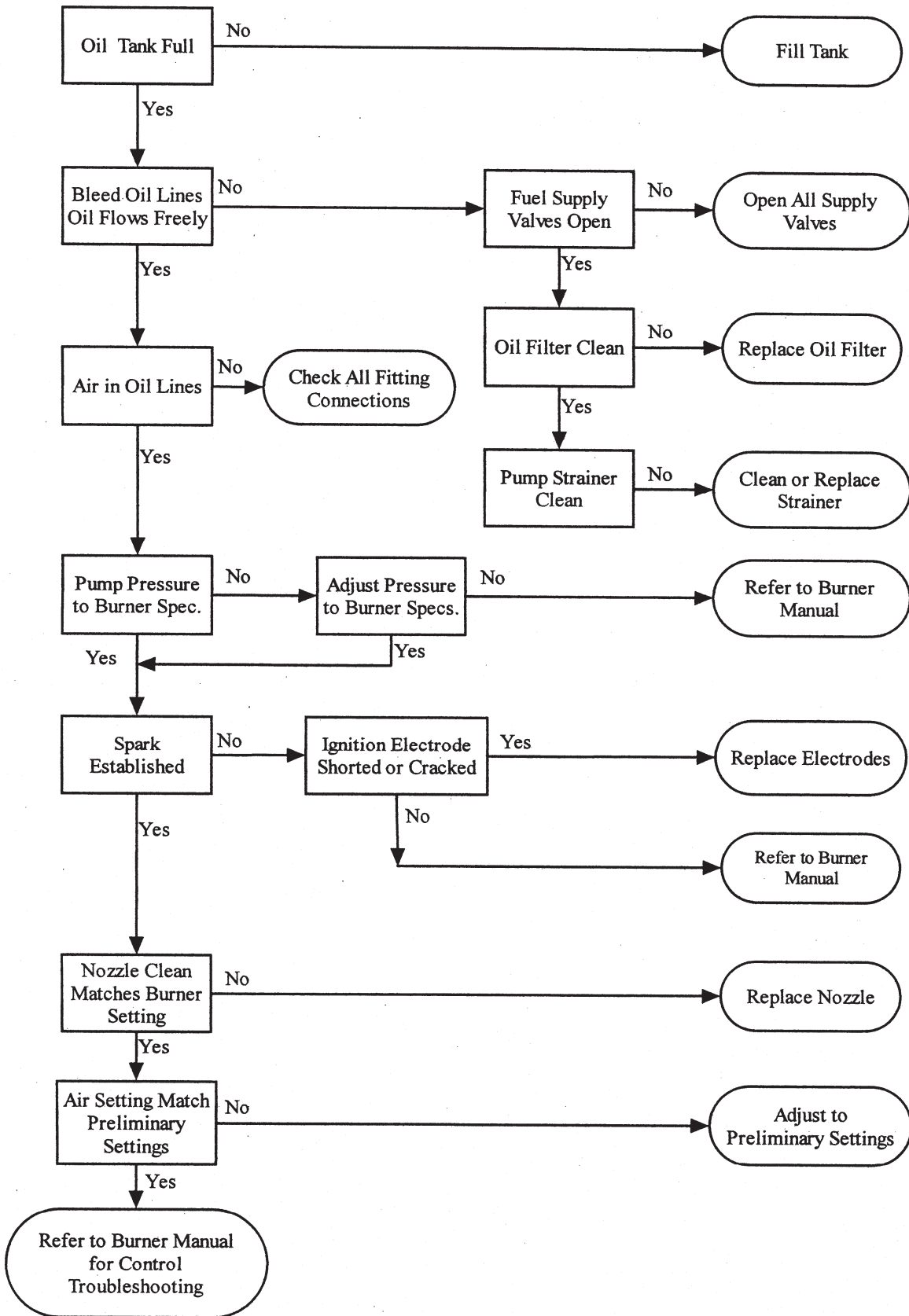

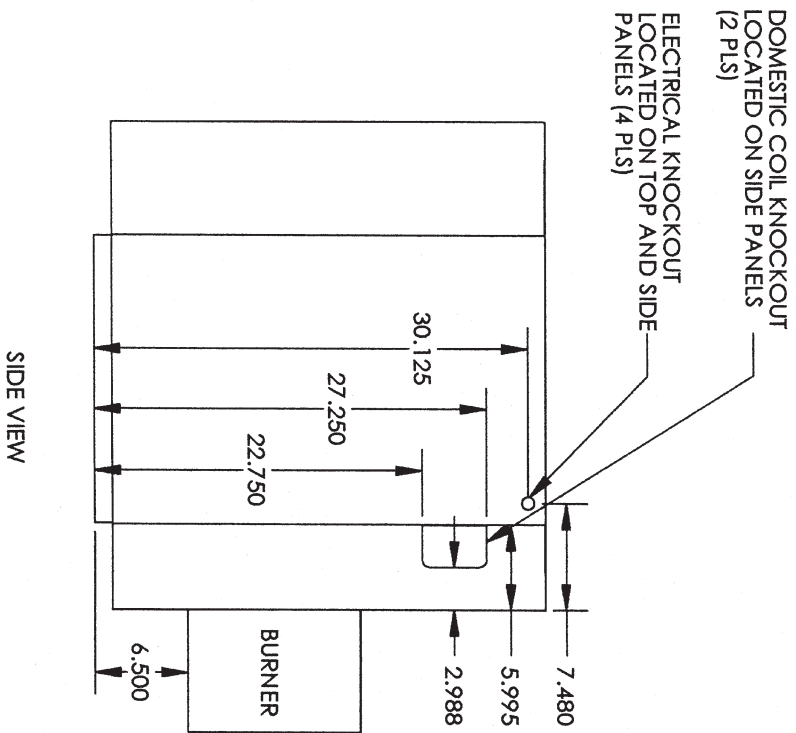
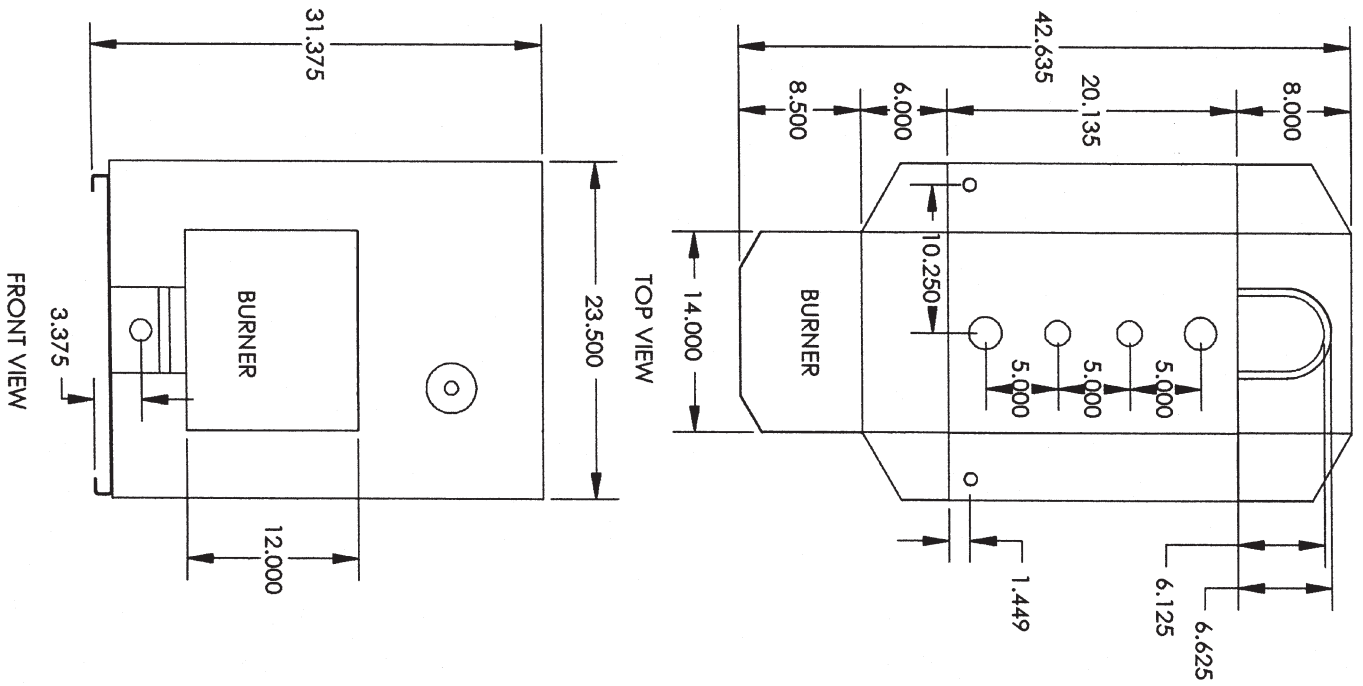

Dimensions Appendix B

Dimensions Appendix B - Condensing Boiler

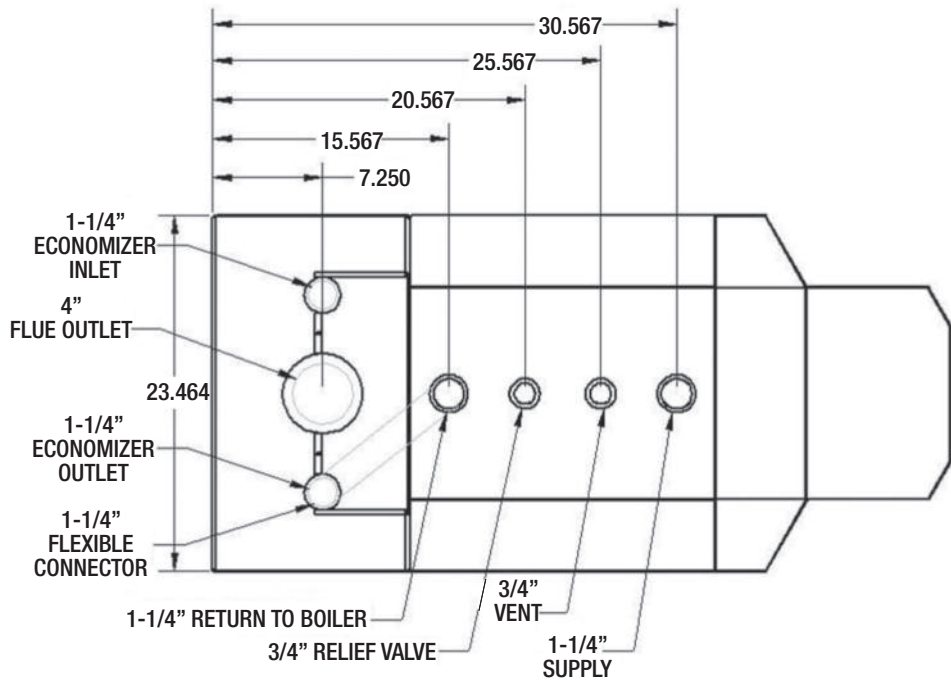
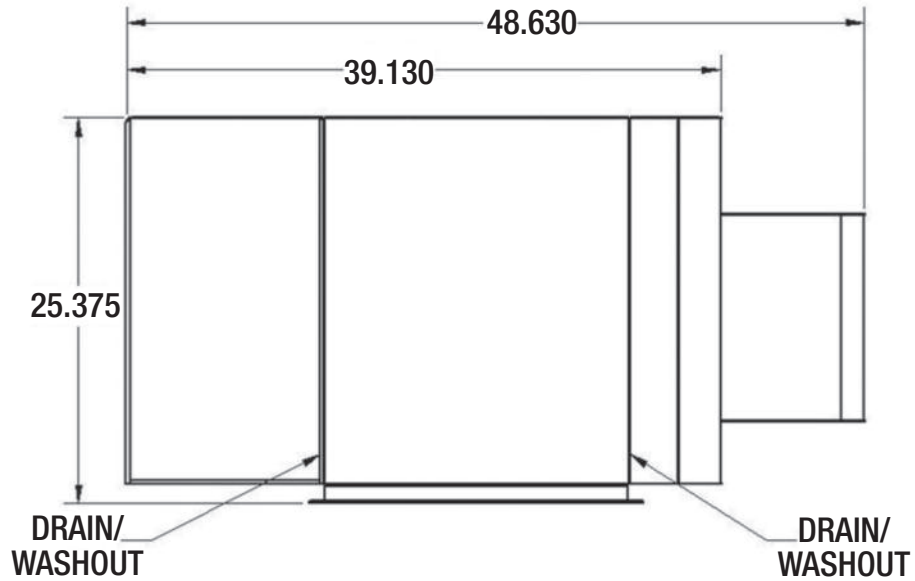

Piping Diagram

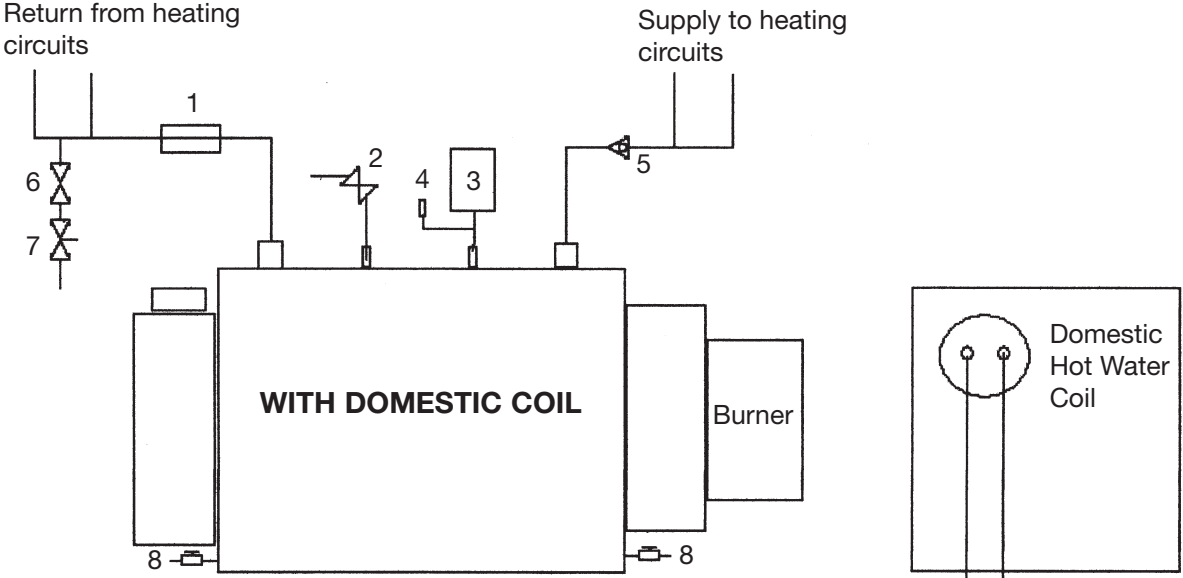

Legend

- 1. Circulator
- 2. Relief Valve
- 3. Expansion Tank Pressurized
- 4. Vent
- 5. Flow Check
- 6. Shut off valve
- 7. Auto Refill/Pressure reducing valve
- 8. Drain
- 9. Tempering Valve
- 10. Manual Bypass Valve
- 11. Optional Danfoss Bypass Valve

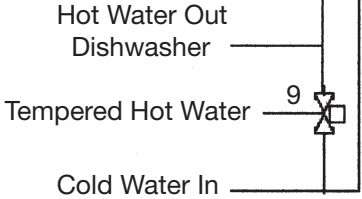

Low Water Cutoff if required, install low water cutoff(s) in the piping anywhere above the top of the boiler. Install in accordance with the manufacturer's instructions.

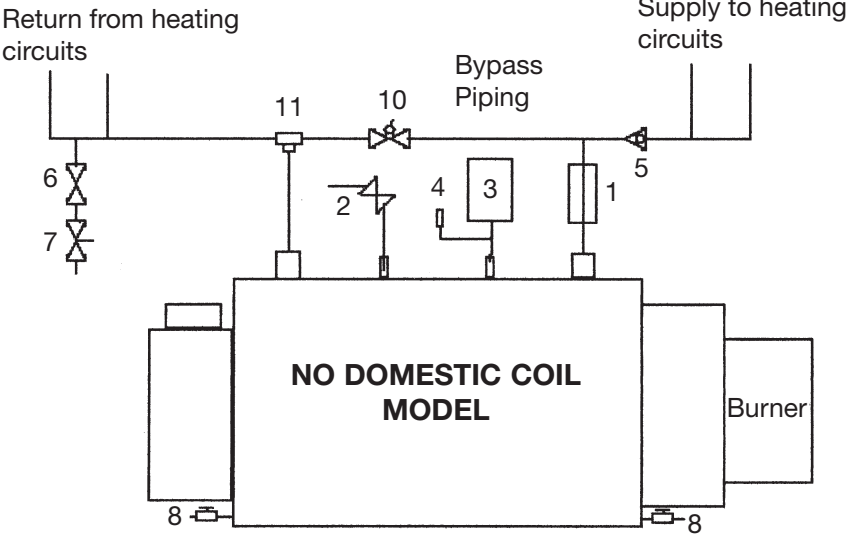

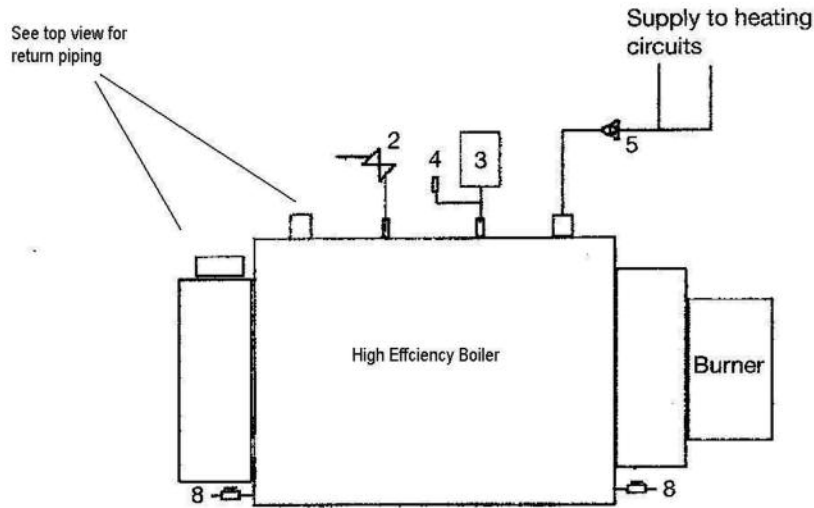

Legend

- 1. Circulator
- 2. Relief Valve
- 3. Expansion Tank Pressurized
- 4. Vent
- 5. Flow Check
- 6. Shut off valve
- 7. Auto Refill/Pressure reducing valve
- 8. Drain
- 9. Tempering Valve

Note: Bypass piping is not required for the high efficiency boiler.

Piping Diagram

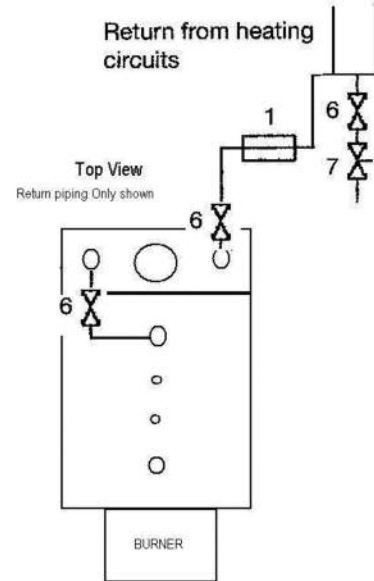

Flanged isolation valves and secondary to primary piping supplied installed with boiler.

Low Water Cutoff
if required, install low water cutoff(s) in the piping anywhere above the top of the boiler. Install in accordance with the manufacturer's instructions.

Appendix C

ELECTRICAL DIAGRAM FOR BOILERS TO CONNECT BURNER TO AQUASTAT (APPLIES TO CARLIN CHIMNEY VENT AND CARLIN DIRECT VENT BURNERS)

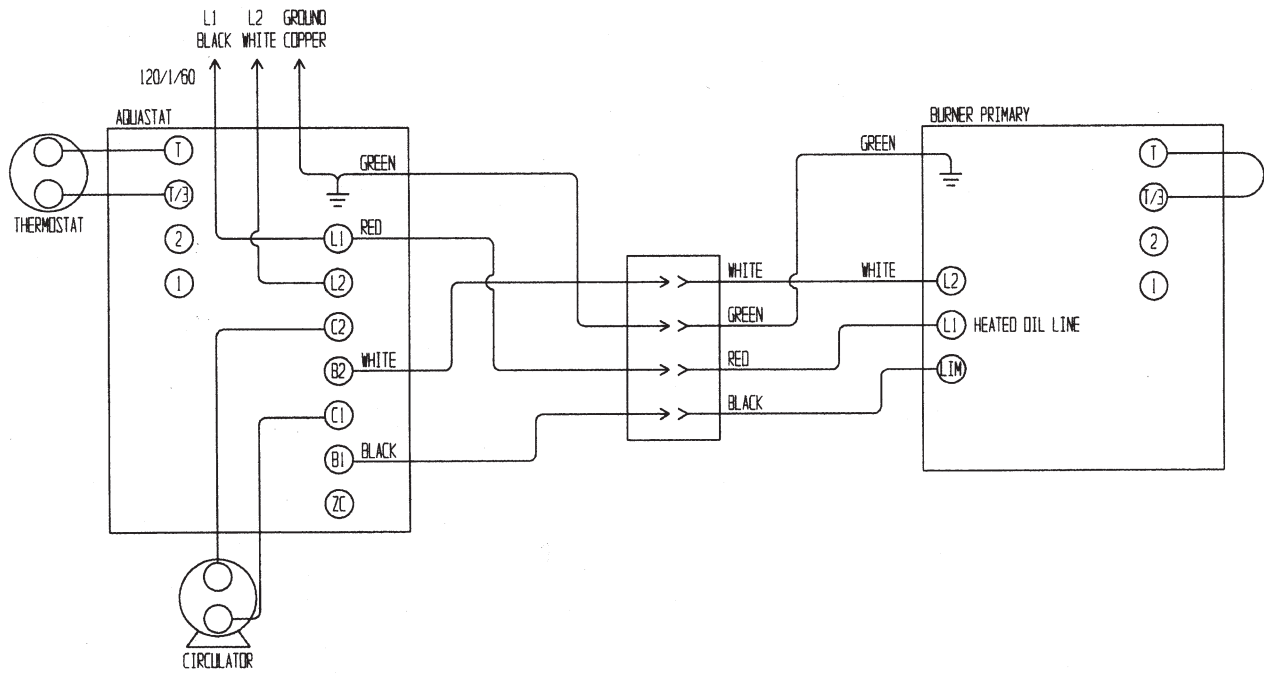

ELECTRICAL DIAGRAM FOR BOILERS TO CONNECT BURNER TO AQUASTAT (APPLIES TO BECKETT CHIMNEY VENT AND DIRECT VENT BURNERS)

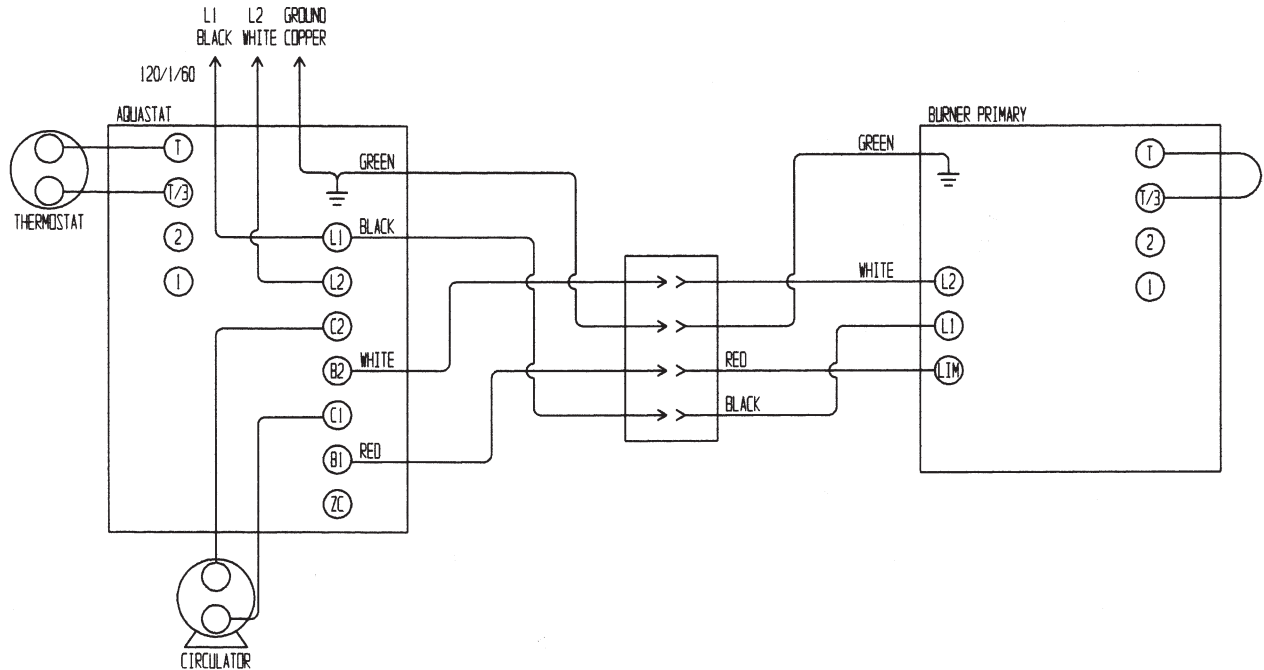

ELECTRICAL DIAGRAM FOR BOILERS TO CONNECT BURNER TO AQUASTAT (APPLIES TO RIELLO CHIMNEY VENT BURNERS)

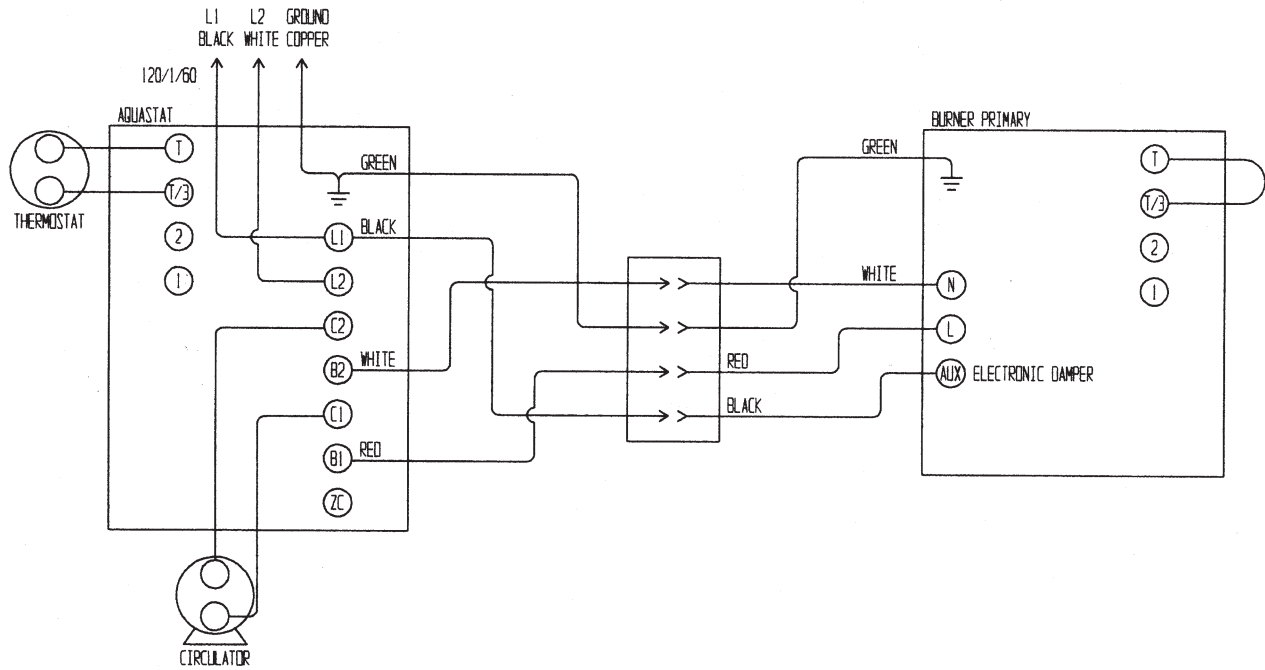

ELECTRICAL DIAGRAM FOR BOILERS TO CONNECT BURNER TO AQUASTAT (APPLIES TO RIELLO DIRECT VENT BURNERS)

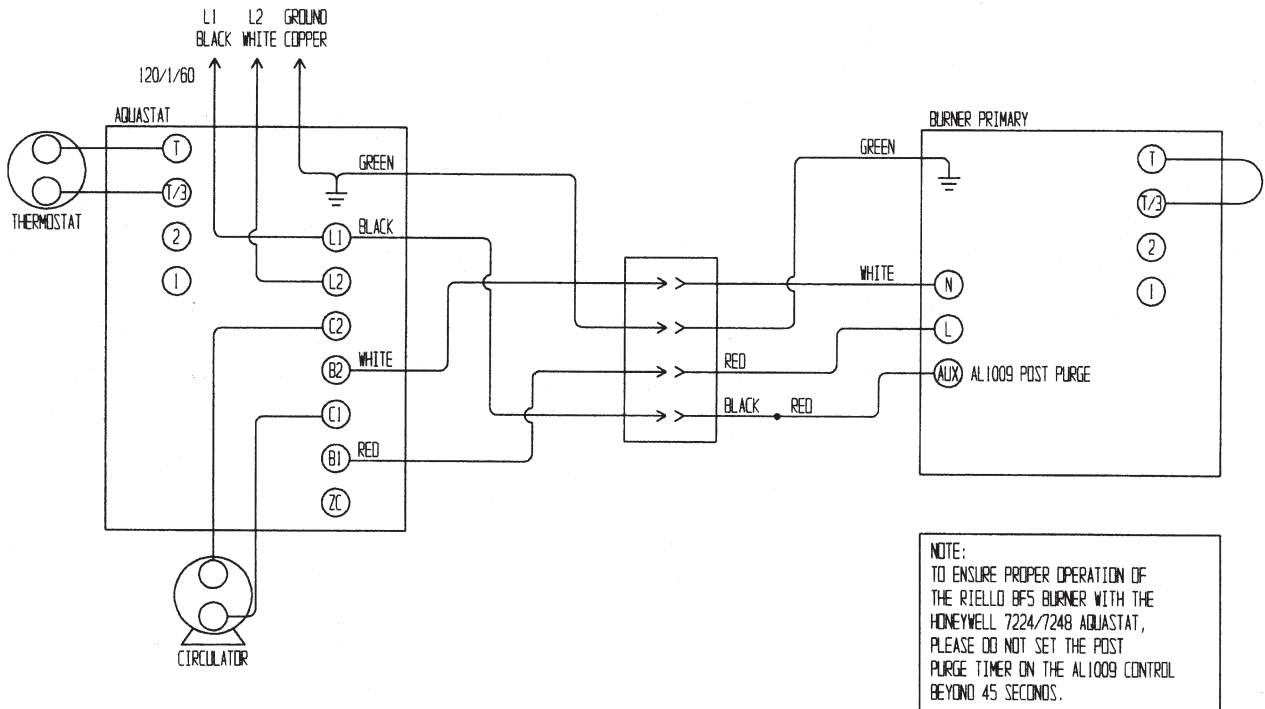

NOTE:
TO ENSURE PROPER OPERATION OF THE RIELLO BF5 BURNER WITH THE HONEYWELL 7224/7248 AQUASTAT, PLEASE DO NOT SET THE POST PURGE TIMER ON THE AL1009 CONTROL BEYOND 45 SECONDS.

BOILER AND BURNER SERVICE SET-UP RECORDS

	Initial Set Up 1	2	3	4	5
1. Date					
2. Model					
3. Firing Rate					
4. Pump Pressure					
5. CO2					
6. "0" Smoke					
7. Gross Stack °F					
8. Draft Over Fire					
9. Replaced Filter Yes/No					
10. Replaced Nozzle Yes/No					
11. Clean Pump Filter Yes/No					
12. Inspect Coil Gasket Yes/No					
13. Check for Leaks					
14. Brush Clean Flue Tube Passages					
15. Vacuum Chamber/Flue Tubes					
16. Clean Blower Wheel					
17. Check Electrodes					
18. Cleaned Secondary Coil. (condensing boiler only)					
19. Replace Condensate Neutralizing Device (condensing boiler only)					
20. Check Condensate Drain Line Clear (condensing boiler only)					

Installation and Service Check List

Boiler Model: _____ Serial No.: _____
Installation Date: _____
Installer Name: _____ Phone No.: _____

Boiler Installation

- Boiler level and in solid contact with floor?
- Boiler and burner wired per wiring diagram and National Electric Code? 120VAC wiring
Type _____ Size _____ AWG
- Burner sealed to boiler? Mounting nuts tight?
- Space is large enough to provide required clearances?
- NFPA 31 Installation of Oil Burning Equipment followed?
- Local, state and national codes, laws, regulations and ordinances followed?

Vent System

- Existing chimney and vent system inspected to NFPA 211 and in good condition?
- New vent pipe installed and properly sealed?
- Vent size checked against furnace manual and codes?
- Condensing Boiler vent to stainless steel chimney liner or direct vent device only.

Burner Operation

- Burner Model: _____ Nozzle: _____ GPH _____ Deg. _____ Type _____
- Burner Pump Pressure: _____
- Fuel Filter and fuel lines installed and inspected as per burner manual?
- Air bled from oil piping? Piping checked for leaks?
- Burner started, adjusted and tested per burner manual?

Boiler Operation

- Thermostat heat anticipator set per burner manual instructions?
- Limit control tested for proper operation?
- Boiler observed going through several operational cycles for proper operation?

Post Installation

- Reviewed owners' information in this manual with owner or maintenance personnel and instructed to keep for future reference?
- Inserted burner manual instructions with boiler manual for future use
- Condensing boilers explain condensate drain operation.

NOTES

NOTES

INSTALLER/SERVICEMAN

Model Number	TDX-WC 90	TDX-WC 100	TDX-WC 110	TDX-WC 125
Burner Type	Beckett	Beckett	Beckett	N/A
Burner Model	NX	NX	NX	N/A
Nozzle Type	0.70 60°B	0.75 60°B	0.85 60°B	N/A
Pump Pressure PSI	175	175	175	N/A
Head/Pin Position	2.5	3.00	4.5	N/A
Air Band	N/A	N/A	N/A	N/A
Air Shutter	N/A	N/A	N/A	N/A
Draft Over Fire	+0.06"	+0.08"	+0.10"	N/A
Draft In Stack	-0.02"	-0.02"	-0.02"	N/A
CO ₂ Reading	10-12%	10-12%	10-12%	N/A
Smoke Reading	ZERO	ZERO	ZERO	N/A

NOTICE

Above settings are approximate. Final adjustments to be made with proper test equipment. Be sure all oil lines are air free and the use of flare fittings is recommended. See installation/service manual for detailed information.

INSTALLER/SERVICEMAN

Model Number	TDX-WC 90 DV	TDX-WC 100 DV	TDX-WC 110 DV	TDX-WC 125 DV
Burner Type	Beckett*	Beckett*	Beckett*	N/A
Burner Model	NX	NX	NX	N/A
Nozzle Type	0.70 60°B	0.75 60°B	0.85 60°B	N/A
Pump Pressure PSI	175	175	175	N/A
Head/Pin Position	2.75	3.25	4.00	N/A
Air Band	N/A	N/A	N/A	N/A
Air Shutter	N/A	N/A	N/A	N/A
Draft Over Fire	+0.080"	+0.115"	+0.125"	N/A
Draft In Stack	+0.040"	+0.055"	+0.065"	N/A
CO ₂ Reading	10-12%	10-12%	10-12%	N/A
Smoke Reading	ZERO	ZERO	ZERO	N/A

*Beckett Air Boot Adaptor

NOTICE

Above settings are approximate. Final adjustments to be made with proper test equipment. Be sure all oil lines are air free and the use of flare fittings is recommended. See installation/service manual for detailed information.

See the label attached to your boiler for data specific to your boiler.

INSTALLER/SERVICEMAN

Model Number	TDX-WC 90	TDX-WC 100	TDX-WC 110	TDX-WC 125
Burner Type	Carlin	Carlin	Carlin	Carlin
Burner Model	EZ-1 PRO	EZ-1 PRO	EZ-1 PRO	EX-1 PRO
Nozzle Type	0.75 60°B	0.85 60°B	0.90 60°B	1.00 60°B
Pump Pressure PSI	150	150	150	150
Head/Pin Position	0.75	0.85-1.00	0.85-1.00	0.85-1.00
Air Band	0.75	0.85	0.90	1.00
Air Shutter	N/A	N/A	N/A	N/A
Draft Over Fire	+0.04"	+0.07"	+0.09"	+0.12"
Draft In Stack	-0.02"	-0.02"	-0.02"	-0.02"
CO ₂ Reading	10-12%	10-12%	10-12%	10-12%
Smoke Reading	ZERO	ZERO	ZERO	ZERO

NOTICE

Above settings are approximate. Final adjustments to be made with proper test equipment. Be sure all oil lines are air free and the use of flare fittings is recommended. See installation/service manual for detailed information.

INSTALLER/SERVICEMAN

Model Number	TDX-WC 90 DV	TDX-WC 100 DV	TDX-WC 110 DV	TDX-WC 125 DV
Burner Type	Carlin*	Carlin*	Carlin*	Carlin*
Burner Model	EZ-1 PRO	EZ-1 PRO	EZ-1 PRO	EX-1 PRO
Nozzle Type	0.75 60°B	0.85 60°B	0.90 60°B	1.00 60°B
Pump Pressure PSI	150	150	150	150
Head/Pin Position	0.75	0.85-1.00	0.85-1.00	0.85-1.00
Air Band	45	40	65	180
Air Shutter	N/A	N/A	N/A	N/A
Draft Over Fire	+0.080"	+0.115"	+0.125"	+0.140"
Draft In Stack	+0.040"	+0.055"	+0.065"	+0.075"
CO ₂ Reading	10-12%	10-12%	10-12%	10-12%
Smoke Reading	ZERO	ZERO	ZERO	ZERO

*Field Control Air Boot Adaptor

NOTICE

Above settings are approximate. Final adjustments to be made with proper test equipment. Be sure all oil lines are air free and the use of flare fittings is recommended. See installation/service manual for detailed information.

INSTALLER/SERVICEMAN

Model Number	TDX-WC 90 DV	TDX-WC 100 DV	TDX-WC 110 DV	TDX-WC 125 DV
Burner Type	Carlin*	Carlin*	Carlin*	Carlin*
Burner Model	EZ-1 PRO	EZ-1 PRO	EZ-1 PRO	EX-1 PRO
Nozzle Type	0.75 60°B	0.85 60°B	0.90 60°B	1.00 60°B
Pump Pressure PSI	150	150	150	150
Head/Pin Position	0.75	0.85-1.00	0.85-1.00	0.85-1.00
Air Band	0.65	0.75	1.00	1.10
Air Shutter	N/A	N/A	N/A	N/A
Draft Over Fire	+0.080"	+0.115"	+0.125"	+0.140"
Draft In Stack	+0.040"	+0.055"	+0.065"	+0.075"
CO ₂ Reading	10-12%	10-12%	10-12%	10-12%
Smoke Reading	ZERO	ZERO	ZERO	ZERO

*Carlin Air Boot Adaptor

NOTICE

Above settings are approximate. Final adjustments to be made with proper test equipment. Be sure all oil lines are air free and the use of flare fittings is recommended. See installation/service manual for detailed information.

See the label attached to your boiler for data specific to your boiler.