

ERGOMAX[®] INSTALLATION

INSTALLATION MUST CONFORM TO LOCAL CODES

1. WITH HYDRONIC BOILERS

All **ERGOMAX[®]** units must be installed vertically. Adjustable feet for leveling are provided.

PRESSURE RELIEF VALVE: Set at 30 psi.

DOMESTIC WATER CONNECTIONS (copper): See tank labels. Cold – in at bottom. Hot – out at top.

TIP: Look into pipe and you will see several small diameter pipes inside.

BOILER WATER CONNECTIONS (steel pipes): See tank labels. Supply – in at top. Return - out at bottom.

SPACE HEATING CONNECTIONS: All E23, E44 and E45 are now made with two extra connections to the boiler water in the tank (for a total of four). See the attached piping schematic and dip tube specifications.

AQUASTAT: Controls water temperature and activates the circulator. Dial shows both Fahrenheit and Centigrade calibrations representing the operating range from 50° to 190°F (10°-83°C). Set the dial to the desired output temperature. (Reference mark is at 12 o'clock). The aquastat can use 110v or 24v. Electrical wires are behind the front cover plate. **WARNING: WATER ABOVE 120° CAN CAUSE SERIOUS INJURY. The installation of a mixing or tempering valve is recommended. See INSTALLING AN ANTI-SCALD valve.**

CIRCULATOR: Between boiler & ERGOMAX unit – calculate circulator flow based on a 20° to 30°F boiler differential. Refer to manual or call GTI for ERGOMAX tank pressure drop.

PRIORITY SWITCH: If one is used, domestic hot water production will have priority over a call for heat.

Installations with above average hot water demand, this will increase the amount of hot water available. It can also be used in conjunction with a mixing or tempering valve to further increase the amount of hot water output.

NOTE: Installation per Schematic A will provide maximum boiler power for heating domestic water without using a priority switch. However, a mixing valve MUST be installed.

BACKFLOW PREVENTER: Some codes require installation of a backflow preventer. In such instances it should be installed in the cold water (domestic) supply line. A system containing a backflow preventer is considered a closed system and a pressure relief valve may have to be installed.

System should be filled with water and air evacuated before starting the boiler. Check that an air vent, expansion tank, gauges, valves, etc., are installed and fully seated to avoid potential leaks. ERGOMAX tank(s) can be filled with water using the boiler makeup water valve or via the drain. Open the pressure relief valve to let the air escape during filling. If the two connections for space heating will not be used, water should come up to the top of these pipes before capping them off (this will ensure that no air is trapped in the connections). All hot water pipes should be installed to prevent heat loss.

ANIT-SCALD valve: Mandatory in the COMMONWEATH OF MASSACHUSETTS.

COMMONWEATH OF PENNSYLVANIA: See NOTE.

SAMPLE SCHEMATICS

Typical residential installations:

A – ERGOMAX units installed in series within a heating loop.

B – ERGOMAX units installed as a heating zone.

Examples of commercial installations:

C – two ERGOMAX units used in a high volume/dual temperature application.

D – ERGOMAX units installed as a heating zone with a storage tank.

IMPORTANT: These are general installation instructions. ERGOMAX units can be installed in other ways. For installation assistance, contact TDC MANUFACTURING, INC.

2. WITH LOW PRESSURE STEAM BOILERS

The general installation process is similar to above but some specifics related to low pressure steam boilers must be taken into account. Please refer to **STEAM INSTALLATIONS** and the accompanying schematic.

ERGOMAX RESIDENTIAL INSTALLATION CONCEPTUAL SCHEMATICS, FOR ILLUSTRATIVE PURPOSES ONLY

ERGOMAX INSTALLED AS A HEATING ZONE

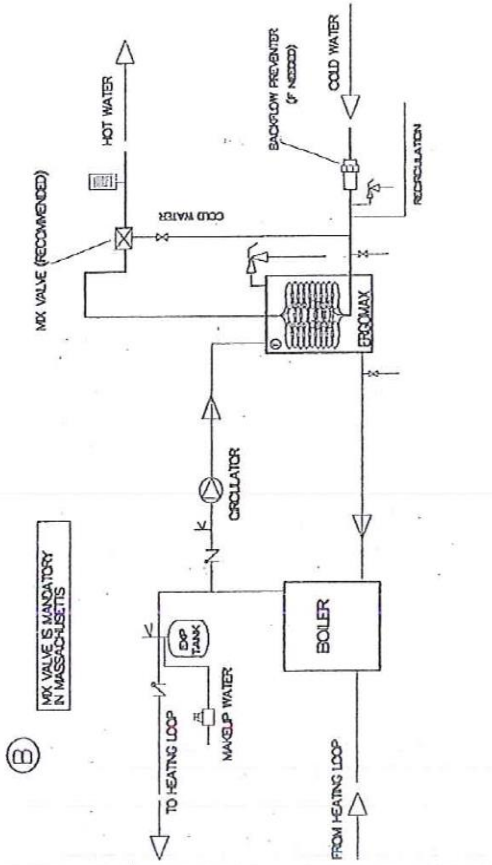
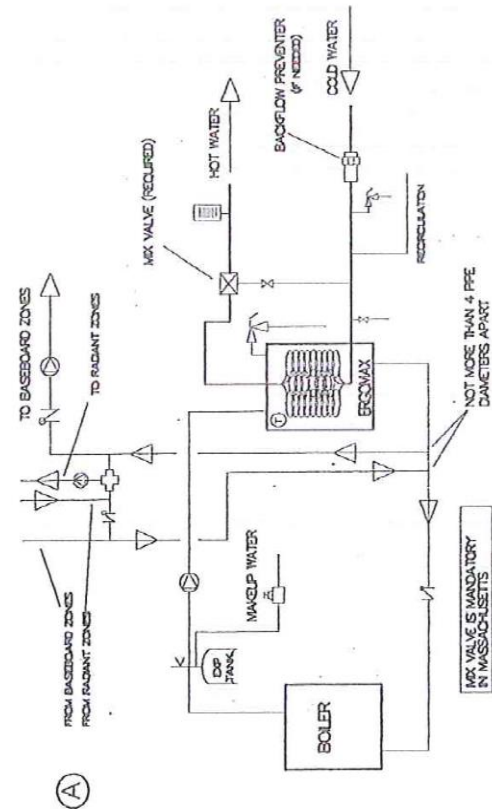

HIGH VOLUME, HIGH/LOW TEMPERATURE APPLICATION

ERGOMAX INSTALLED AS A HEATING ZONE, W/STORAGE TANK

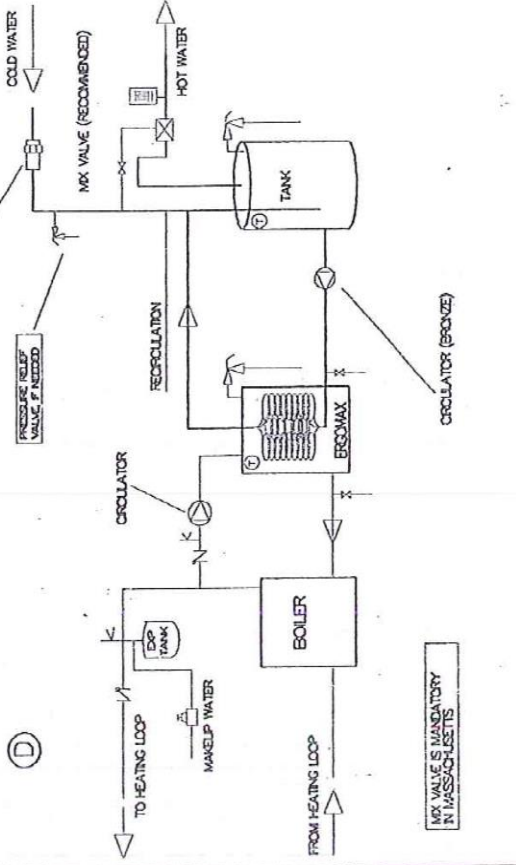
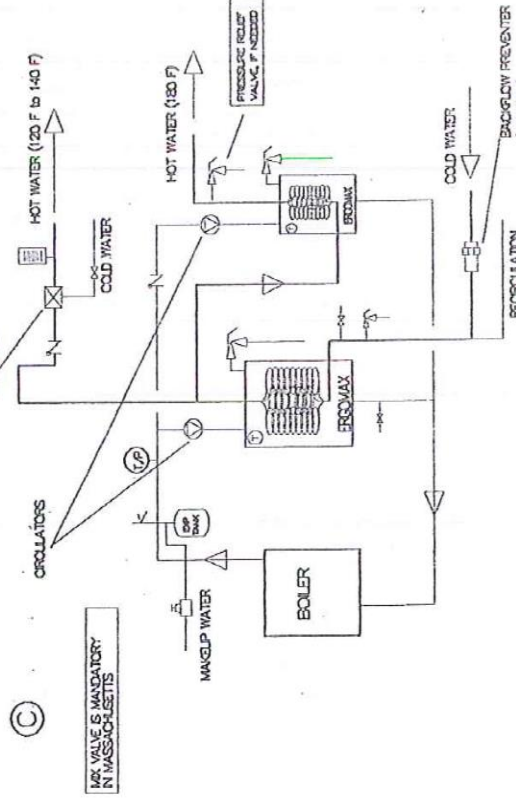

SHUT OFF	CHECK VALVE	TEMP. PRESS. GAUGE	TEMP. GAUGE	ACTUATOR	PRESS. RELIEF VALVE	NOT TO SCALE	INS-ALL 02/05
----------	-------------	--------------------	-------------	----------	---------------------	--------------	---------------

STEAM INSTALLATIONS

General: Boiler water in the piping and ERGOMAX unit may be at a higher level than the water level in the steam boiler. It will not flow back into the boiler if all air is eliminated from the entire boiler/ERGOMAX unit loop.

ERGOMAX units can be installed with low pressure steam boilers by using the water below the steam as boiler water supply for ERGOMAX units. However, some precautions must be taken:

1. There should be no air vents on the system. An expansion tank is not needed.
2. ERGOMAX units must be isolated from the boiler with ball valves to fill it with water.
3. A ball valve should be placed on the boiler supply pipe to let the air out of the ERGOMAX tank during the fill process. (See following schematic.) Note: the pressure relief valve could also be used for this purpose. However, the seating must be perfect; else air will get into the system.
4. The offtake for boiler water supply must be well below the water line in the boiler (at least 9 inches). If it is too close to the water level the circulator may suck air or steam with the boiler water when it starts up. This air could accumulate in the ERGOMAX tank, reducing performance and causing the tank to rust and eventually to fail. An indication that this is occurring is the water level in the sight glass bobbing up and down when the circulator is running. To eliminate this problem, the offtake should be moved further below the waterline in the boiler. If this is not possible, one of the ball valves (preferably downstream of the circulator for the ERGOMAX unit zone) should be shut down somewhat to minimize the movement of water in the sight glass. Be careful not to close the ball valve too much as this will restrict the flow of boiler water to the ERGOMAX tank, lowering this performance.
5. Sludge. Sludge tends to accumulate in steam boilers over time. (Add conditioner annually to control acidity and sludge formation.) This sludge may also be pumped into ERGOMAX unit via the circulator and accumulate at the bottom of the ERGOMAX tank. To prevent sludge accumulation in the ERGOMAX unit: a) the boiler should be flushed before ERGOMAX unit is installed and at the beginning of each heating season; and b) a strainer/filter must be installed on the boiler water supply to ERGOMAX unit and cleaned at regular intervals. (See following schematic.) Accumulation of sludge in ERGOMAX unit will cause the ERGOMAX tank to fail. The Warranty does not cover failure due to sludge accumulation. Check for any sludge accumulation at regular intervals by opening the tank drain on ERGOMAX unit. If sludge is present, flush the boiler and ERGOMAX tank and make sure the strainer is clean.

NOTE: be very careful when draining the tank as this water is very hot. Isolate ERGOMAX unit from the boiler by closing the ball valves, refill with water and evacuate all air.

6. Water in steam boilers tends to become acidic. Boiler water conditioner should be added to the boiler water annually to keep acidity within the normal Environmental Protection Agency (EPA) recommended range of between pH 6.5-8.5. If this is not done, the warranty will be voided.
7. An anti-scald valve is mandatory in the COMMONWEALTH OF MASSACHUSETTS.

INSTALLING AN ANTI-SCALD VALVE

We recommend that anti-scald valves (conforming to ASSE 1017) be installed as part of all domestic hot water installations for two reasons:

1. To maximize boiler operating efficiency. To obtain the greatest benefit from a boiler/ERGOMAX unit combination (particularly a low mass boiler) the boiler should operate at maximum efficiency. This happens when a boiler does not short cycle. Such an operating environment can be established by maximizing ERGOMAX unit's thermal storage capacity, e.g., operating ERGOMAX unit at a relatively high temperature and using an anti-scald valve to keep the domestic water temperature within the normal use range.
2. ERGOMAX units can produce very high temperature water which could pose a scalding danger. Installing an anti-scald valve will prevent this from happening.

To maximize protection from possible scalding, many local plumbing codes require anti-scald valves be installed on all water heaters. **Get into the habit of opening the cold water faucet first and then the hot water one.**

NOTE

In the Commonwealth of Pennsylvania ERGOMAX heat exchangers, when the heat input per ERGOMAX is greater than 200,000 btu/hr, do not require code construction when relieved by an ASME 15 psi safety relief valve. When such a valve is installed one must make sure that the expansion tank is adequate to handle the extra volume of boiler water in the ERGOMAX tank, else the relief valve will "blow off" from time to time. When such a valve is installed it is recommended that the circulator be installed on the boiler return between ERGOMAX and the boiler.

Installing ERGOMAX Heat Exchanger with a Low Pressure Steam Boiler

— BOILER WATER, RED
 — DOMESTIC WATER, BLUE

ANTI SCALD VALVE IS MANDATORY
 IN MASSACHUSETTS

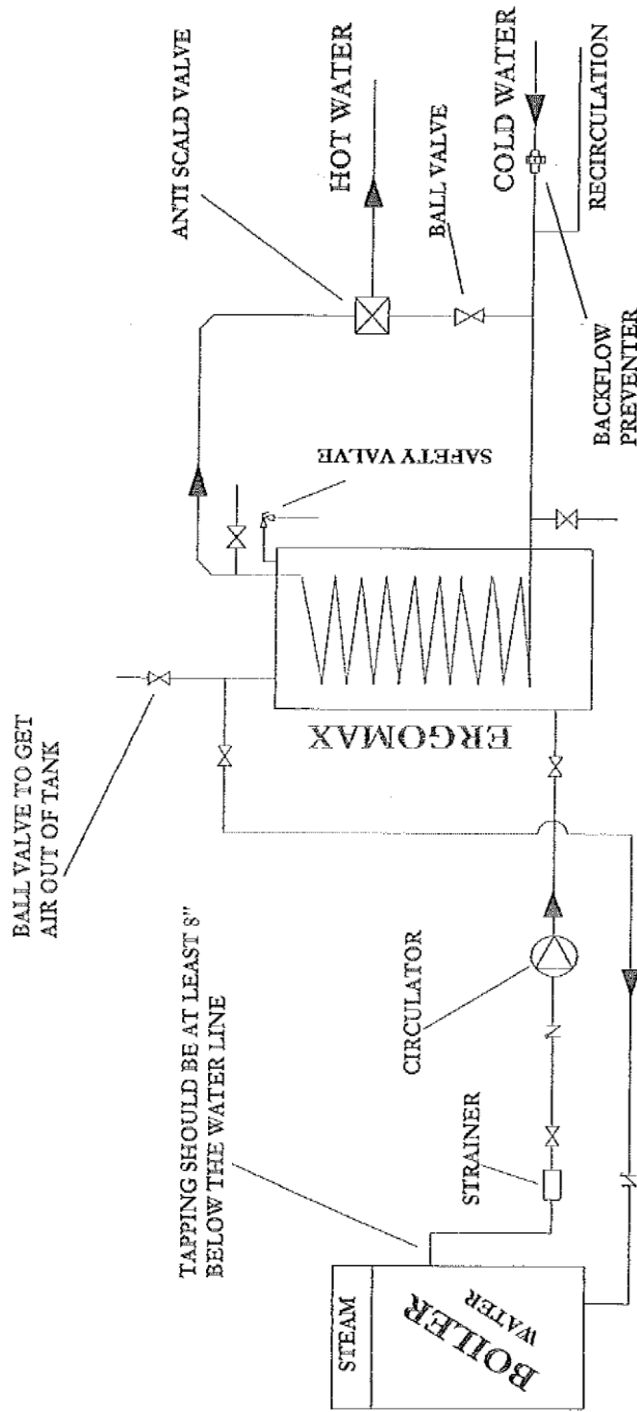

CONCEPTUAL SCHEMATIC FOR,
 ILLUSTRATIVE PURPOSES ONLY

WIRING DIAGRAM FOR OIL FIRED WATER BOILER

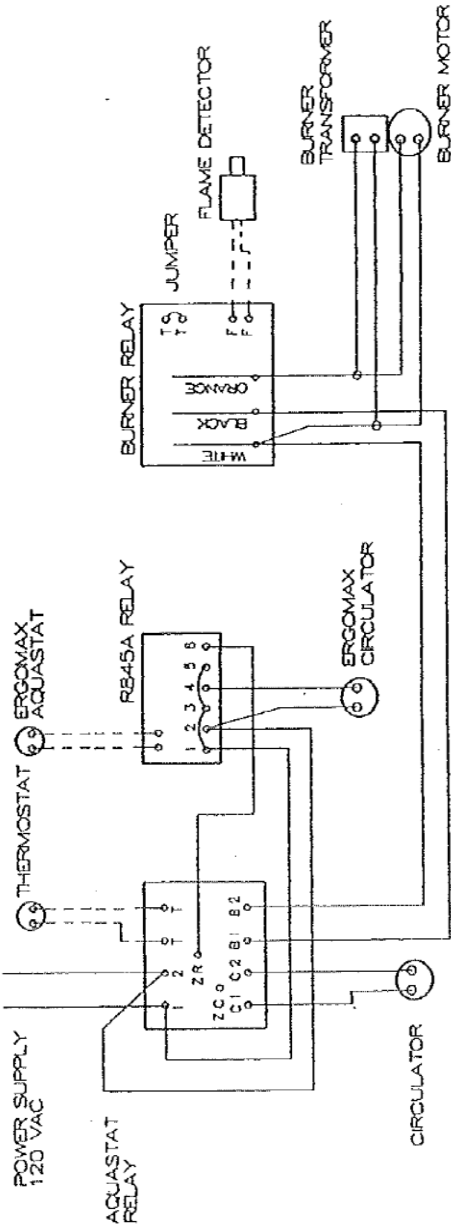

EL-OL 01/01

WIRING DIAGRAM FOR GAS FIRED WATER BOILER

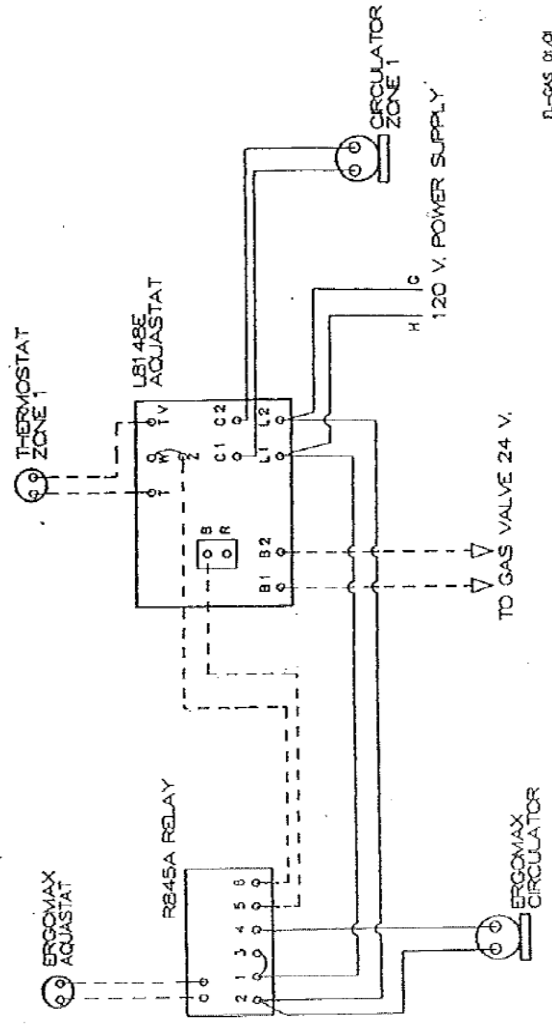

GAS CONTROLS - 24 V.
FORCED HOT WATER - 2 ZONE
NO TANKLESS COIL

--- 24 VOLTS
___ 120 VOLTS

EL-GAS 01/01

TROUBLE-SHOOTING CHECK LIST

<u>PROBLEM</u>	<u>PROBABLY CAUSE</u>	<u>SOLUTION</u>
No hot water	Boiler does not operate	<ul style="list-style-type: none"> - Press reset button - Check fuse - Check main cut off switch
	Circulator does not operate Zone valve does not open Improper setting on aquastat Electrical problem	<ul style="list-style-type: none"> - Check power supply - Check power supply - Turn aquastat to a higher temperature - Check relay, fuse and replace - Reset circuit breaker (if applicable) - Check power supply - Check all wiring
Not enough hot water	Inoperative aquastat	<ul style="list-style-type: none"> - Set aquastat to higher temperature and see if circulator starts to operate. Replace aquastat if needed
	Air trapped in ERGOMAX tank	<ul style="list-style-type: none"> - Open safety valve on top of ERGOMAX to let air out
	Aquastat set to low	<ul style="list-style-type: none"> - Turn aquastat to a higher setting & install mix valve
	Demand greater than boiler output	<ul style="list-style-type: none"> - Check sizing calculation
Water temperature starts to drop	Defective aquastat	<ul style="list-style-type: none"> - Replace
	Insufficient boiler output (Btu) with no priority for DHW	<ul style="list-style-type: none"> - Reduce hot water flow rate. Install priority switch. Install mix valve
	Air trapped in ERGOMAX tank	<ul style="list-style-type: none"> - Open pressure relief valve on top of ERGOMAX to let air out
Water temperature too hot	Aquastat set too low	<ul style="list-style-type: none"> - Set aquastat to higher temperature
	Boiler undersized, no priority for DHW	<ul style="list-style-type: none"> - Install priority switch
	Demand for hot water greater than boiler Btu output	<ul style="list-style-type: none"> - Check boiler/ERGOMAX sizing calculations - Reduce hot water flow rate, check boiler/ERGOMAX sizing calcs.
Water temperature too hot	Water pressure is very high	<ul style="list-style-type: none"> - Install pressure reducing valve. Set to 60-65psi
	Aquastat set too high	<ul style="list-style-type: none"> - Set aquastat to lower temperature - Install and set mix valve to lower temperature - Check aquastat operation. (As aquastat is set to lower temperature, circulator should stop.)
	Defective aquastat	<ul style="list-style-type: none"> - Replace aquastat
	Check mix valve	<ul style="list-style-type: none"> - Clean mix valve
Sound of rushing water when circulator starts	Improper plumbing	<ul style="list-style-type: none"> - Check plumbing against installation instructions
	Improper system wiring	<ul style="list-style-type: none"> - Check wiring
	Air in piping and/or tank	<ul style="list-style-type: none"> - Open safety valve to let air out. Install air vent on last elbow in piping leading into the tank
Gurgling sounds in ERGOMAX	Air in tank	<ul style="list-style-type: none"> - Open safety valve to let air out. Install air vent on last elbow in piping leading into the tank.
Coils making a noise	Air in tank	<ul style="list-style-type: none"> - Open safety valve to let air out.
Surges of hot/cold water in shower	Shower fixture problem	<ul style="list-style-type: none"> - Check pressure balancing valve operation
Pressure relief valve opens occasionally	Pressure on boiler side too high	<ul style="list-style-type: none"> - Lower boiler pressure
		<ul style="list-style-type: none"> - Check pressure relief valve operations - Check is expansion tank has failed
Pressure relief valve discharges often	Pressure on boiler side too high	<ul style="list-style-type: none"> - Could indicate coil failure. Call your plumber
Boiler cycles too often	Boiler high limit set too low	<ul style="list-style-type: none"> - Set high limit higher
	Electrical wiring	<ul style="list-style-type: none"> - Check aquastat/boiler control wiring
Tank leak	Boiler control	<ul style="list-style-type: none"> - Check boiler control operation
	Aquastat	<ul style="list-style-type: none"> - Check aquastat operation
	Determine location	<ul style="list-style-type: none"> - Check tank drain for leak - Call your plumber to determine location (aquastat well not tight, safety valve leaking, temp/pressure gauge not tight, tank leak)

ERGOMAX® Heat Exchangers

Suggested Piping Schematic

All ERGOMAX models E23, E44 and E45 are now produced with two extra connections to the boiler water in the tank. This improvement allows **boiler water in the ERGOMAX tank** to be used not only to **heat domestic water**, but also for **space heating, both radiant and baseboard/radiators, and to buffer boilers**, eliminating short cycling and saving fuel. ERGOMAX installation below, primarily for residential applications, shows the suggested piping.

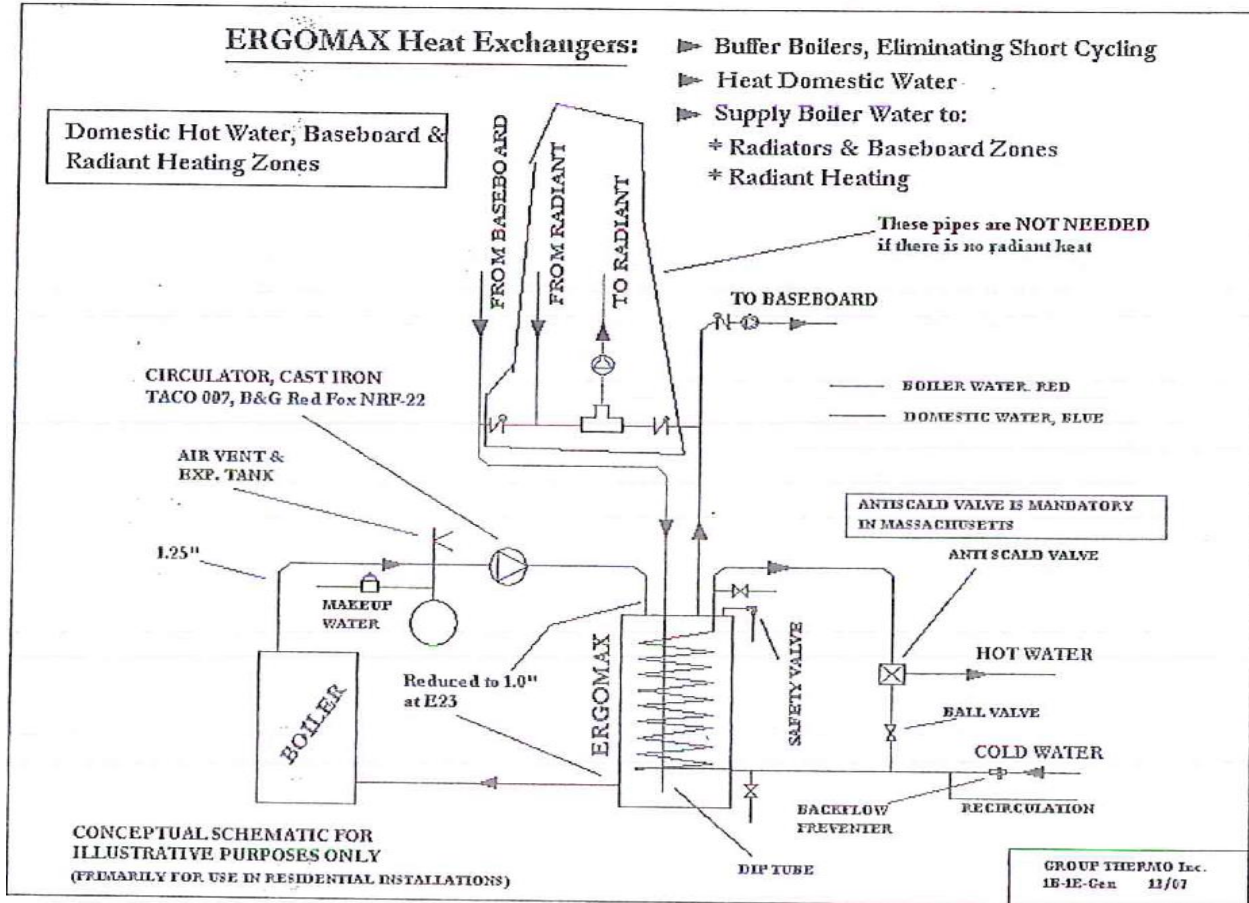

The dip tube is built into all models.

Replacing the ERGOMAX® Aquastat

Switch off the boiler and electrical power to the aquastat. Isolate ERGOMAX from boiler by closing boiler side valves and undo the electrical connections to the aquastat.

If the ERGOMAX Jacket is square:

1. Remove cover plate. The aquastat is in a well, and there is no need to drain the tank. Carefully loosen the small capillary lock nut and unscrew it. Next unscrew the plug from the well. Remove the bulb from the well.
2. Pull the aquastat control knob from the spindle and remove the aquastat control box by unscrewing the two small screws. Remove aquastat.
3. Insert the new bulb into the well. **Note:** make sure that the bulb can go all the way into the well. The end of the bulb must touch the end of the well to ensure good contact. (if the capillary is coated with plastic, carefully remove enough plastic to make sure that the bulb will go all the way into the well.) Screw the plug into the well. **Tighten the capillary lock nut in the plug only slightly, else the capillary may be pinched and cause the aquastat to malfunction.** (The lock nut only needs to hold the capillary in place since the well is a dry well.)
4. Install the electrical wires on the control box contacts, install the control on the panel (be careful not to kink/damage the capillary), reinstall the cover onto the front panel and reconnect the aquastat electrical wires. Replace the temperature control knob.
5. Open the ball valves, set temperature on ERGOMAX. System is ready for operations.

If the ERGOMAX jacket is round:

1. The tank must be drained. Connect a hose to the drain valve at the bottom of ERGOMAX. Drain the tank by opening the drain valve and open the pressure relief valve on top of the tank to let air in. The other end of the hose should be placed into a drain. **Be very careful – the water from the tank will be hot.**
2. Unscrew the compression fitting through which the capillary enters the tank and carefully pry out the washers/rubber gasket (to be reused). Pull the bulb out.
3. Pull the aquastat control knob from the spindle and remove the aquastat control box by unscrewing the two small screws. Remove aquastat.
4. Install the new aquastat by putting the bulb through the flange well into the tank. Reinstall the washers and gasket and screw in the plug. Do not over tighten as it will pinch the capillary and cause the aquastat to malfunction.
5. Install the control box (be careful not to kink/damage the capillary) and reconnect the aquastat electrical wires.
6. Close the drain and refill ERGOMAX tank with water by opening the ball valves. This will fill ERGOMAX with fresh water via the boiler make up water valve. **Make sure the pressure relief valve is open to let the air out.** When the tank is full, water will start to flow through the pressure relief valve. Close the relief valve. Make sure there is no leak at the aquastat fitting. Reinstall the front cover. Switch on the electric power to the aquastat and set aquastat to desired temperature. The aquastat should call for heat and the boiler should fire.

Note: Water above 120°F may cause scalding and severe burns. We strongly recommend that an anti-scald valve be installed on the hot water output pipe.

LIMITED LIFETIME WARRANTY

In **residential** service the Manufacturer warrants to the original retail Purchaser that the tank and coil assembly shall be free of leaks for fifteen years in the home in which ERGOMAX® was originally installed, provided that: a) the acidity of the water is within the normal Environmental Protection Agency (EPA) recommended range of between pH 6.5-8.5; b) the domestic water does not contain abnormal levels of particulate matter; and c) water hardness does not exceed 10.5 gpg. Residential service shall mean use in dwellings with no more than two apartments. Warranty will also be voided when installed with low pressure steam boilers if sludge is allowed to accumulate in ERGOMAX tank and boiler water acidity is outside the levels indicated above.

In **commercial** service the Manufacturer warrants the tank and copper coil assembly for ten (10) years, the first five (5) years in full and years six (6) through ten (10) prorated 20% each year at the prevailing retail price, provided water and sludge prevention conditions defined above are met. Commercial service shall mean use in other than residential service.

Units are not covered from damage which may occur due to flooding. In the event of tank leakage due to defective material or workmanship, such leak having been verified by an authorized company representative, Manufacturer will repair or replace the failed unit with a comparable ERGOMAX unit available at the time of replacement at no cost to the original retail Purchaser, except as set forth in this Warranty. The repaired or replacement unit may have changes in design, material or construction which in the judgment of Manufacturer constitute an improvement of former practice. The original Purchaser is responsible for all costs associated with the removal and reinstallation, shipping and handling to and from Manufacturer. The replacement unit will be warranted for the remaining portion of the original Warranty.

Component Parts Warranty

Controls are warranted by the respective original equipment manufacturer for a period of one (1) year.

Exclusions and Limitations

This Warranty shall apply only if:

1. ERGOMAX is installed according to the installation instructions provided with the unit.
2. Any failure or malfunction does not result from improper or negligent operation, accident, abuse (including freezing), misuse, unauthorized alteration or improper repair or maintenance.
3. The unit is used in the United States.
4. The consumer presents a copy of the original sales receipt at the time claim is filed. (For first occupant of a new home, the date of closing will be deemed the date of purchase.)
5. This Warranty shall be void if the manufacturer's tag has been tampered with or removed from the ERGOMAX without written permission from TDC MANUFACTURING, INC.

ERGOMAX & BUFFER TANK REGISTRATION CARD

To activate Warranty, please complete and mail within 30 days

Model: _____ Serial Number: _____

Installation Date (m/d/y) _____ / _____ / _____

Type of Use (circle one): Home / Duplex / Apartment Bldg / Commercial

Owner's Name: _____

Installation Address: _____

City: _____ State: _____ Zip: _____

Telephone: _____ Installer: _____

Mail Registration Card to: TDC MANUFACTURING, INC. 155 Route 61 South, Schuylkill Haven, PA 17972